

The above photo is the ALCO builder's photo of new #2, a RS-3 built for American Smelting and Refining. AM&R's RS-3s worked their complete service life at the large smelter west of Salt Lake City. The 1600 Horse power units were built in 1950, for AM&R serial numbers #2 78371, #3 78372. Kennecott Copper Corp. took over the smelter operations in 1959, both units worked for Kennecott until replaced by EMD MP15AC's.

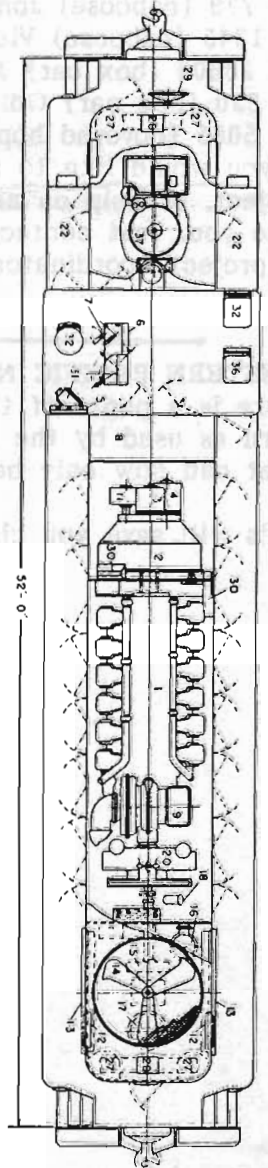
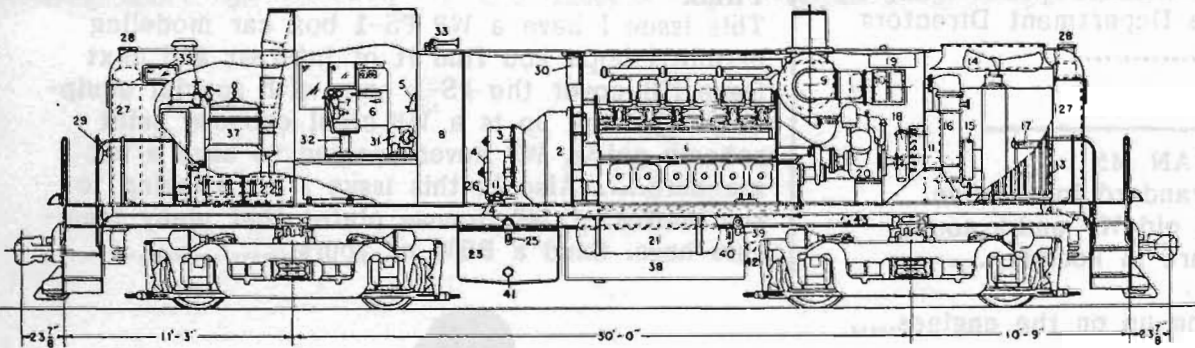

- |   |                              |                                  |   |
|---|------------------------------|----------------------------------|---|
| 1- ENGINE                                     | 11- TRACTION MOTOR BLOWERS   | 22- BATTERIES                    | 33- HORN                                |
| 2- MAIN GENERATOR                             | 12- RADIATORS                | 23- FUEL TANK                    | 34- BELL                                |
| 3- EXCITER                                    | 13- RADIATOR SHUTTERS        | 24- FUEL TANK FILLING CONNECTION | 35- NUMBER BOXES                        |
| 4- AUXILIARY GENERATOR                        | 14- RADIATOR FAN             | 25- FUEL TANK GAUGE              | 36- CAB SEAT (MOD)                      |
| 5- GAUGE PANEL                                | 15- RADIATOR FAN CLUTCH      | 26- EMERGENCY FUEL CUT OFF       | 37- STEAM GENERATOR (MOD)               |
| 6- CONTROL STAND                              | 16- LUBRICATING OIL COOLER   | 27- SAND BOXES                   | 38- WATER TANK (MOD)                    |
| 7- BRAKE VALVES                               | 17- LUBRICATING OIL FILTERS  | 28- SAND BOX COVER               | 39- WATER TANK FILLING CONNECTION (MOD) |
| 8- CONTROL COMPARTMENT                        | 18- LUBRICATING OIL STRAINER | 29- HAND BRAKE                   | 40- WATER TANK GAUGE (MOD)              |
| 9- TURBO SUPERCHARGER                         | 19- ENGINE WATER TANK        | 30- GENERATOR AIR DUCTS          | 41- FUEL TANK DRAIN                     |
| 10- TURBO SUPERCHARGER<br>FILTERS & SILENCERS | 20- AIR COMPRESSOR           | 31- CAB HEATER                   | 42- ENGINE OIL DRAIN                    |
|   | 21- MAIN AIR RESERVOIR       | 32- CAB SEATS                    | 43- ENGINE WATER FILL                   |