

# SNOW PLOW!

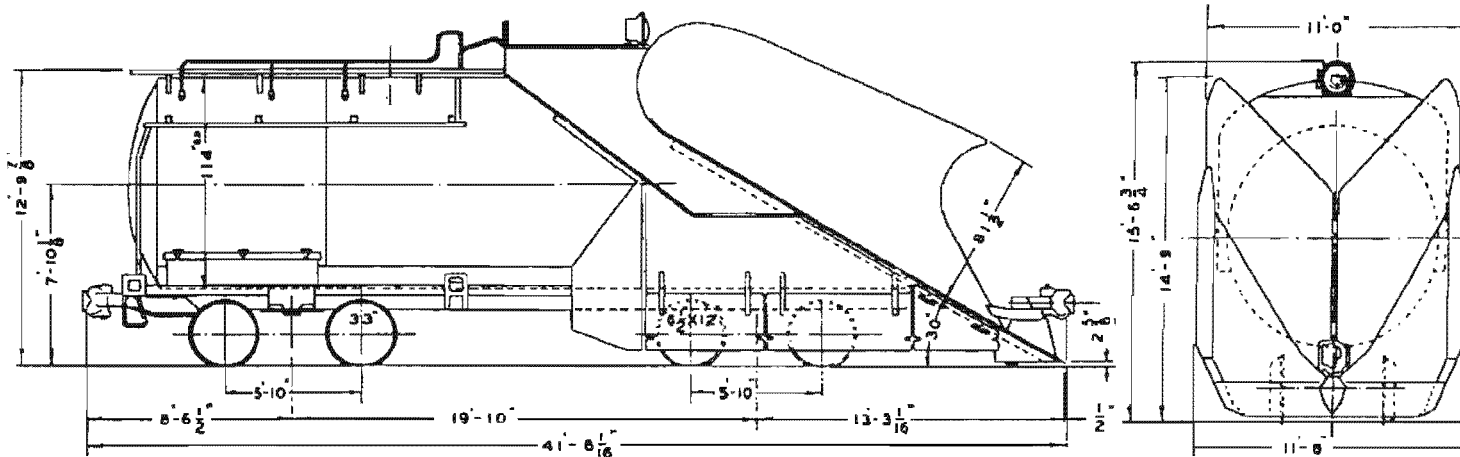

## Engine Tender Snow Plows

By James L. Ehernberger

This article is reprinted and condensed from The Union Pacific Historical Society's official publication, "The Streamliner" and used with their written permission.

The winter of 1948-1949 went into the record books as the nastiest and longest snow blockade in the history of the Union Pacific. It was obvious that it was going to be a long winter in Kansas and Nebraska as early as November of 1948. Unusually heavy snow conditions also existed in Idaho and Utah, long before the early January tie-up between Buford, Wyoming, and Sidney, Nebraska, marooning numerous Streamliner and standard passenger trains at several towns along this route. On February 6th, another storm plagued the area west of Laramie, extending half way across Wyoming beyond the Continental Divide, where through trains were unable to move for nearly two weeks. For more than six weeks, and no less than six storms later, the most expensive and dreadful winter ever recorded had occurred.

Snow fighting equipment was challenged to its fullest capacity. Many pieces did not survive the battle, while the remaining equipment required major repairs by the time Spring finally arrived.

Every possible type of equipment was called out to conquer huge snow drifts. No expenses were spared. Employed in the day and night task were 15 rotary plows, 33 wedge and spreader plows, 124 flame throwers and 180 bulldozers.

Prior to the storm, the Union Pacific had 19 wedge snow plows available, mostly single track type except for three double track plows. These were wooden bodied and most (except for two) had wood underframes. The most modern of these wedge plows was built on a flat car in 1928, while the majority dated back to between 1914 and 1920.

During this winter alone, four single track type wedge snow plows were demolished in accidents. On November 21, 1948, plow number 03018 was wrecked at Hoxie, Kansas; in Nebraska, during January of 1949, the 03030 was wrecked at Hoagland on the Kearney Branch (resulting in the fatality of a train employee) and the 03031 was wrecked at Belgrade on the Cedar Rapids Branch. On February 8, 1949, wedge plow 03029 shoved by engine 3947 was derailed and demolished at MP 613.6 west of Wilcox, Wyoming, compounding existing problems on this portion of the railroad.

Because of its aging fleet of wedge plows, the damage encountered during this winter, and the inability to keep lines open, mechanical department correspondence indicates that management took a closer look at this equipment and a program for improvement or replacement was soon underway.

A requisition had been approved to convert twelve 12,000 gallon (four wheel truck) tenders into snow plows and materials were on order for this conversion as early as April.

The first tender converted into a snow plow was outshopped at Cheyenne in July. It was considered the "initial or sample" conversion and, if satisfactory would be extended to complete the order for the 12 plows, of which eight were to be single track and four were to be double track types.

Snow plow and flanger parts were applied to the converted tenders from several of the soon-to-be-retired wood underframe snow plows.

It was originally planned to construct the single track plows at Cheyenne and the double track types at Pocatello. It ended up that Cheyenne constructed four single track plows (numbered 05-08 with flanger cabs and four double track models (numbered 020-023) while Pocatello built four single track plows (numbered 01-04) without cabs.

Another important stage in development was the ballasting of the snow plows. In addition to the light weights, it was necessary to

locate 6" diameter drain holes in bottom of tank along centerline, so there was a drain between each tee. Each 6" diameter hole was covered with smoke box netting welded in place. Placement of larger size rock ballast over each drain to prevent possible clogging of drain with finer ballast was necessary.

Dry Granite rock ballast was placed in water space of tender tank up to bulkhead to form back support for snow plow frame. Size of Granite rock ballast was 1/2" to 1-3/4", weight 2400 lbs. per cubic yard. For a trial weight, the ballast was level at top of swash plates, then the plow was weighed again, front, back and total, and Omaha furnished these figures.

It was determined upon completion of the ballasting as indicated, Omaha would advise the amount of additional rock ballast to be placed in tank, and the weight of scrap lead or iron ballast to be placed in compartment between front wall of cab and center line of front bolster.

A 1/4" cover plate over ballast compartment was applied. Final weights were furnished after all ballast and cover plates were placed. Finally, necessary adjustment of blocks was made to the front truck so that the nose of the plow measured 2-5/8" above top of rail and the shoe 1-1/8" above top of rail.

Instructions were also issued in the event it was necessary to lift the plow end of the tender due to derailment, i.e., at the front end sill of the tender frame. For this purpose, the side skirt doors of the plow adjacent to the front end sill are removable. Wood blocking should be used where sling cable contacts base of the snow plow.

In 1950, the Chief Engineer recommended Johnson's green label floor wax be applied to all wedge snow plows, which provides a surface similar to a polished plow, and when plows are running frequently it preserves the smooth surface which in effect causes snow to clear the plow at a greater speed. Master mechanics along the system were instructed to make arrangements to order and apply wax to all plows assigned to their territories as soon as material was available at local stores.

No. 02, single track type, built 09-1949 at Pocatello, ID, Original tender No. 12-C-213 from original engine No. 3562, wedge from 03018 which was originally built 11-1916 as 076 and vacated 02-1949, weight on front truck 114,700, weight on back truck 114,720, total weight 229,420, renumbered 900002 in 12-1959.

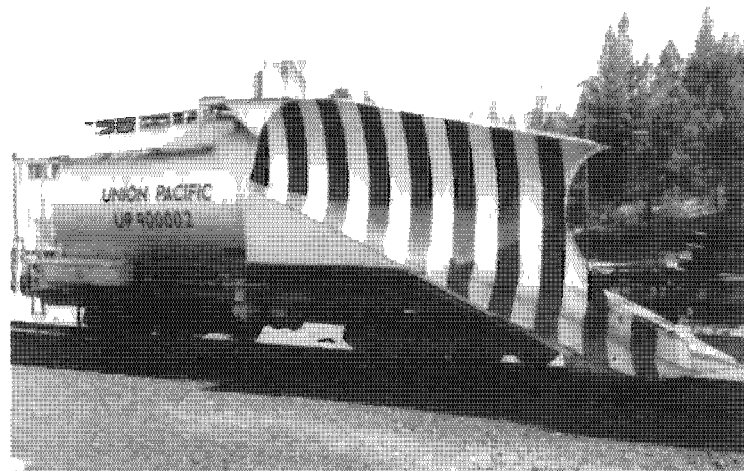

Snow Plow UP 900002 shown here at the museum with the side skirts removed from the front truck, and with roller bearings.