

LOCOMOTIVE & FREIGHT  
EQUIPMENT

SACRAMENTO  NORTHERN RAILWAY  
AND

TIDEWATER SOUTHERN RAILWAY

*LOCOMOTIVE & FREIGHT  
EQUIPMENT*

*TIDEWATER SOUTHERN RAILWAY*

Nos. T.S. 744 -745  
 DATE BUILT - No.744, 1948  
 - No.745, 1949

MODEL - ALCO S-2  
 POWER PLANT

1-1000 H.P. DIESEL ELECTRIC UNIT  
 DIESEL ENGINE A.L.Co. 539  
 6-12½"x13" CYLS. VERT. 4 CYCLE

GENERATORS

1-G.E. D.C. TYPE 553C  
 1-G.E. EXCITER, TYPE GMC. 139AC

## DIESEL-ELECTRIC SWITCHING 8-WHEEL

TRACTION MOTORS

4-G.E. D.C. TYPE 731  
 GEAR RATIO 75:16

CONTROL EQUIPMENT  
 G.E. TYPE P

AIR COMPRESSOR

1-WESTINGHOUSE TYPE 3-CD

BRAKE EQUIPMENT

WESTINGHOUSE EL-14  
 CLASP BRAKES

FUEL - DIESEL OIL ..... 635 GALS.

LUBE OIL ..... 80 "

ENGINE COOLING WATER ..... 240 "

SAND ..... 2700 LBS.

TRACTION EFFORT - 57,500 LBS.

MAX. PERMISSIBLE SPEED 60 MPH.

MAX. TRACK CURVE 50 FT. RADIUS

ROAD CLASS 744  
 SYMBOL S-57

WEIGHT IN WORKING ORDER  
 (INCL. FULL FUEL OIL, LUBE OIL,  
 WATER, SAND, EQUIPMENT &  
 CREW) - 230,000 LBS.

AXLE LOAD - 57,500 LBS.

TOTAL LIGHT WEIGHT. 220,100

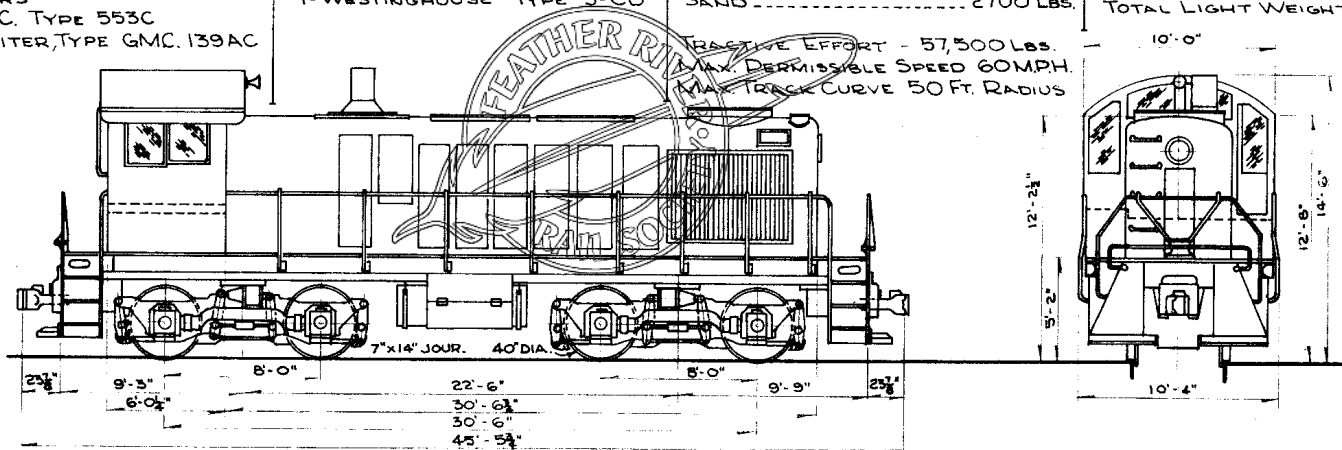

Nos. T.S. 746-747

DATE BUILT - 1949.  
MODEL - ALCO RS-1.  
POWER PLANT:

1000 H.P. - 6 CYLINDER  
DIESEL ENGINE, VERT, 4  
CYCLE, 12 1/2" BORE x 13" STROKE,  
MODEL 539.

GEAR RATIO - 75:16.

### DIESEL-ELECTRIC ROAD SWITCHER

#### GENERATORS:

- (1) MAIN - G.E. GT553
- (1) AUXILIARY - G.E. GMG139
- (1) EXCITER - G.E. GMG139

#### TRACTION MOTORS:

- (4) G.E. - TYPE 731

#### AIR COMPRESSOR:

- (1) WABCO - TYPE 3-120

#### BRAKE EQUIPMENT:

WABCO - EL-14

CLASP BRAKES

FUEL - DIESEL OIL ... 1600 GAL.

ENG. LUBE OIL ... 80 GAL.

ENG. WATER ... 240 GAL.

SAND ... 27 CU. FT.

TRACTION EFFORT ... 61,800 LBS.

ADHESION ... 25%

SPEED ... 60 MPH.

MAX. TRACK CURVE ... 100 FT. RADIUS

SYMBOL S61

#### WEIGHT IN WORKING

ORDER (INCL. FULL FUEL

& LUBE OIL, WATER, SAND,

EQUIPMENT) - 247,400 LBS.

AXLE LOAD - 61,850 LBS.

LIGHT WEIGHT - 230,400 LBS.

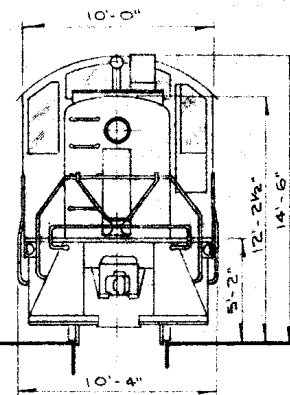
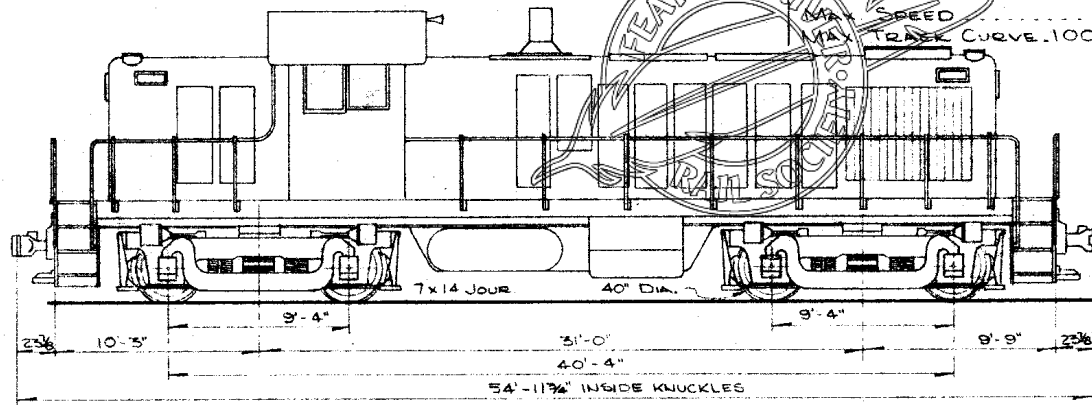

UNITS PREVIOUSLY  
SPOKANE INTERNATIONAL  
Nos. 1218 & 1216

BUILDERS LOT NO 01-5124

DROP BOTTOM GONDOLA, CLASS GS  
BUILT BY AMERICAN CAR & FOUNDRY CO.  
AFE T.S. 5-57

CAR NOS T.S. 201-205  
ORIG NO OF CARS 5

ALL CARS EQUIPPED WITH  
LUBRICATOR PADS

POWER HAND BRAKE

OTHER SIDE  
- 10-8 STAKES  
- 10-7 1/2 OVER CORNER  
- 9-9 1/2 INSIDE

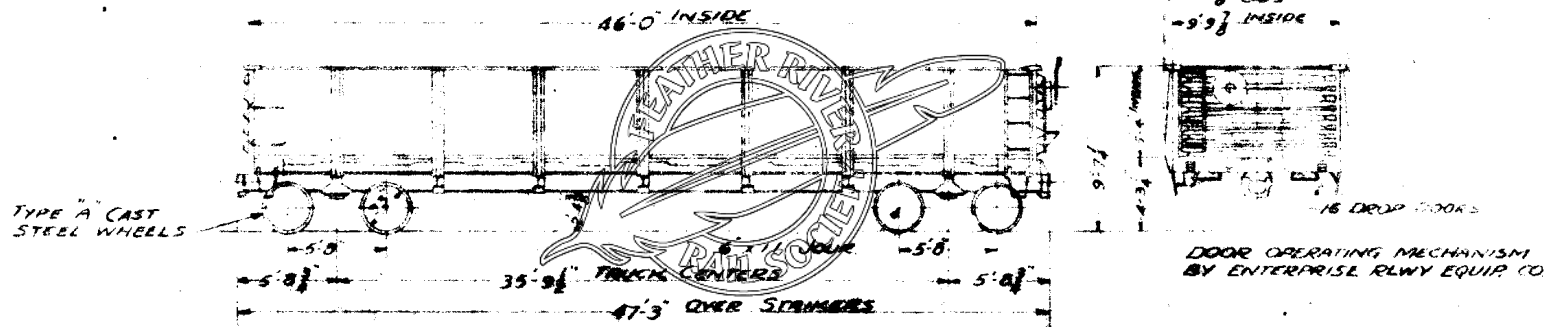

ASF A-3 RIDE CONTROL TRUCKS  
CARDWELL-WEST NY-11-F DRAFT GEAR  
WESTINGHOUSE TYPE AB 1012 AIR BRAKES

LENGTH INSIDE 46'-0"  
WIDTH " 9'-9 1/2"  
HEIGHT " 5'-8"

CAPACITY 140000 LBS  
" 2410 CUFT  
LEVEL FULL

WEIGHT - BODY TRUCKS  
TOTAL 56300 LBS

RWC 4-23-50

BUILDERS LOT NO. 8240

BOX CAR, CLASS XM  
 BUILT BY PULLMAN STANDARD CAR MFG. CO.  
 AFE T.S. 23-55.

CAR NOS. T.S. 501-525  
 ORIG. NO. OF CARS 25

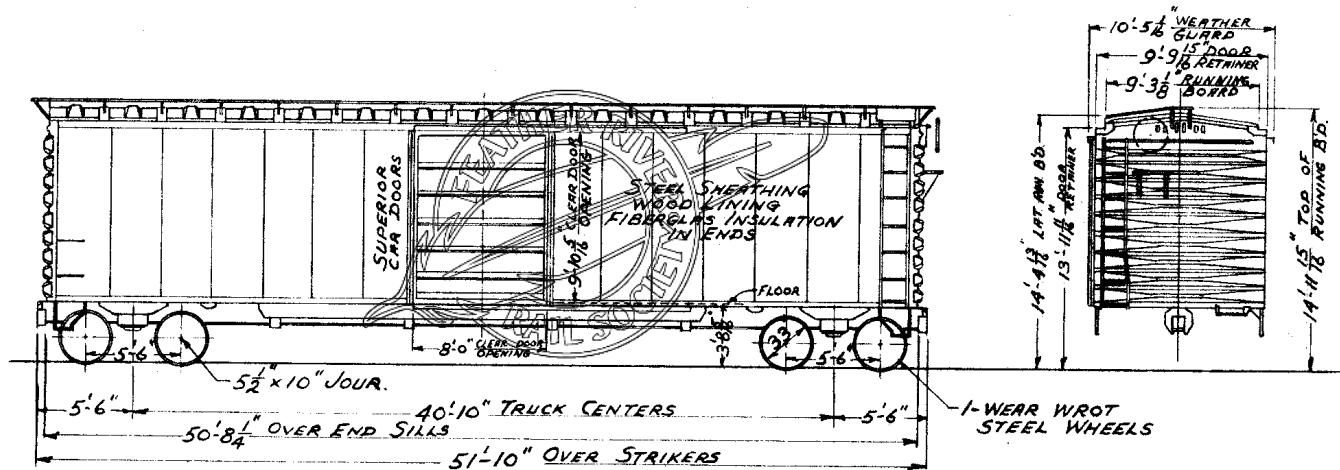

SCULLIN A-3 RIDE CONTROL TRUCKS  
 N.M. & S.C. CO. TYPE MF-275 RUBBER DR. GEAR  
 WESTINGHOUSE TYPE AB-1012 AIR BRAKES

LENGTH INSIDE	50'-5 7/8"
WIDTH	9'-2 1/8"
HEIGHT	10'-5 1/2"

CAPACITY	10000 LBS.
	4844 CU. FT.

WEIGHT - BODY
TRUCKS
TOTAL 52000 LBS

BUILDERS LOT No WP-57.

INSULATED BOX CAR, CLASS RBL  
 BUILT BY PACIFIC CAR & FOUNDRY CO.  
 AFE T.S. 17-57.

CAR NOS. T.S. 601 - 610  
 ORIG. No. OF CARS 10

TS 601-605, 1 WEAR WROT STL. WHEELS  
 TS 606-610, TYPE "A" CAST STL. WHEELS  
 CARS EQUIPPED WITH PC LOADERS:  
 TS 601-608, 8 BELTS  
 TS 609-610, 6 BELTS.

ROLLER BEARINGS 601-605 606-610  
 DRAFT GEAR HYATT TIMKEN  
 FR-16 MF-400

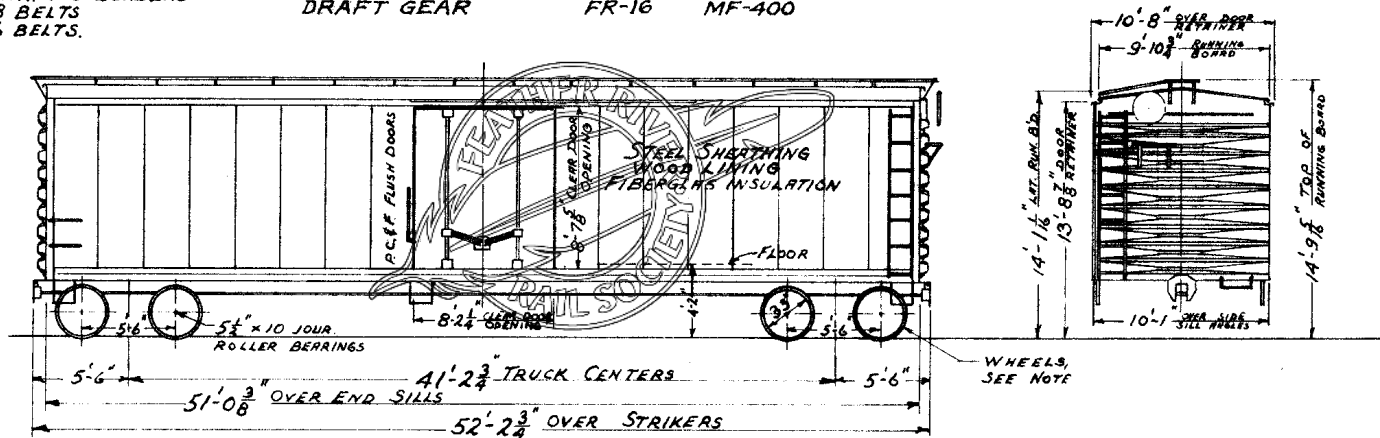

BARBER STABILIZED, TYPE S-2-C TRUCKS  
 RUBBER DRAFT GEAR-SEE TABLE  
 WESTINGHOUSE TYPE AB-1012 AIR BRAKES

LENGTH INSIDE ---- 50'-0"  
 WIDTH " ---- 9'-2"  
 HEIGHT " ---- 9'-1"

CAPACITY ---- 97000 LBS.  
 " ---- 4154 CU. FT.

WEIGHT - BODY  
 TRUCKS  
 TOTAL 70900 LBS

BUILDERS LOT NO WP-58

INSULATED BOX CARS, CLASS RBL  
 BUILT BY PACIFIC CAR & FOUNDRY DEC. 1958  
 AFE T.S. 2-59

CAR NOS. T.S. 611-620  
 T.S. 801-840  
 NO OF CARS 50

NOTE:

TS 611-620 EQUIPPED WITH 6 BELT PC LOADERS - WIDTH INSIDE 9'-2" - TOTAL WT. 70200 LBS.

TS 801-840 EQUIPPED WITH 8 BELT DF LOADERS - WIDTH INSIDE 9'-1 $\frac{3}{4}$ " - TOTAL WT. 71400 LBS.

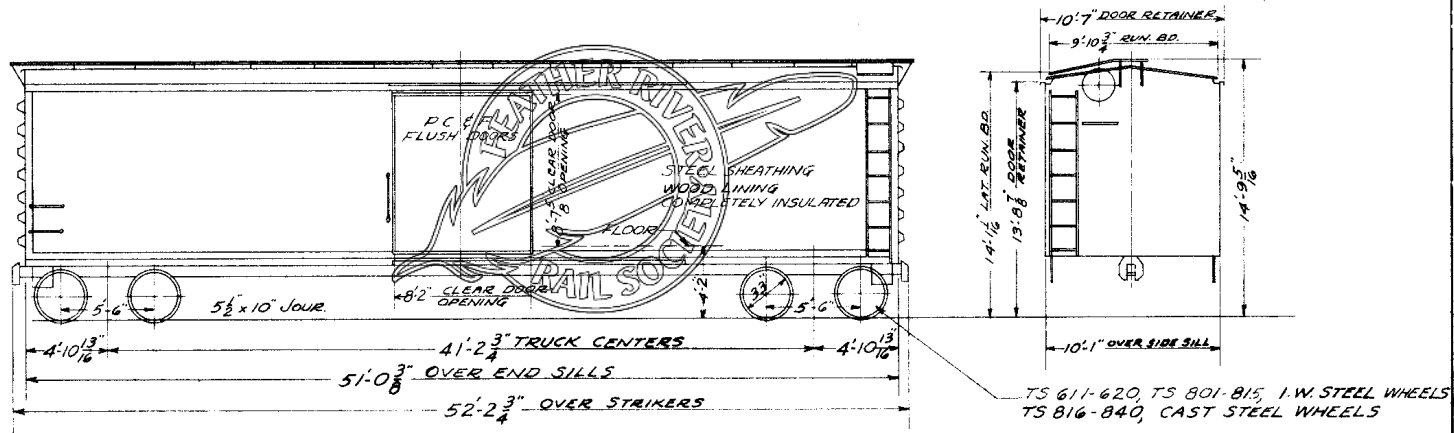

BARBER S-2-C STABILIZED TRUCKS  
 N.M. & S.C. Co. MF-400 RUBBER DRAFT GEAR  
 AAR FRICTION BEARINGS

LENGTH INSIDE	50'-6"
WIDTH	SEE NOTE
HEIGHT	9'-1"

CAPACITY 97000 LBS.  
 " 4154 CU. FT.

WEIGHT BODY  
 TRUCKS 14590  
 TOTAL SEE NOTE



LOCOMOTIVE & FREIGHT  
EQUIPMENT  
SACRAMENTO-NORTHERN RAILWAY

SACRAMENTO-NORTHERN

SN.RY. Nos. 144-146 No. of LOCO'S 3  
 BUILT-GEN ELEC. CO.  
 LOCO'S. 144-146 1946

# DIESEL-ELECTRIC SWITCHING 8-WHEEL ROAD CLASS SN-142

SYMBOL S-26

FUEL-DIESEL OIL

\* WEIGHTS IN WORKING ORDER  
 TOTAL ON DRIVERS 88,000 LBS.

TOTAL DRY (LIGHT) WT. 84,900 LBS.  
 AXLE LOAD 22,000 LBS.

## POWER PLANT

2-190 H.P. CATERPILLAR DIESEL  
 ENGINES TYPE D-17000  
 8-5 $\frac{1}{2}$  x 8" CYLS. "V" TYPE, 4 CYCLE

## GENERATORS

2-G.E. DIRECT CURRENT TYPE GT-555

2-G.E. EXCITER TYPE G.M.G.-140

## TRACTION MOTORS

4 G.E. DIRECT CURRENT TYPE G.E.-733

GEAR RATIO 11.25 TO 1

## AIR COMPRESSOR

2 GARDNER-DENVER TYPE ADS.

## BRAKE EQUIPMENT

WESTINGHOUSE A.B. Co. STRAIGHT  
 AND AUTOMATIC SCHEDULE 14-EL

FUEL-DIESEL OIL ----- 250 GALS.

LUBR. ----- 100 GALS.

ENGINE COOLING WATER. 80 GALS.

SAND ----- 800 LBS.

TRACTIVE POWER 26,400 LBS.

MAX. PERMISSIBLE SPEED 35 M.P.H.

MAX. TRACK CURVE 50 FT RADIUS

REV. 8-20-70

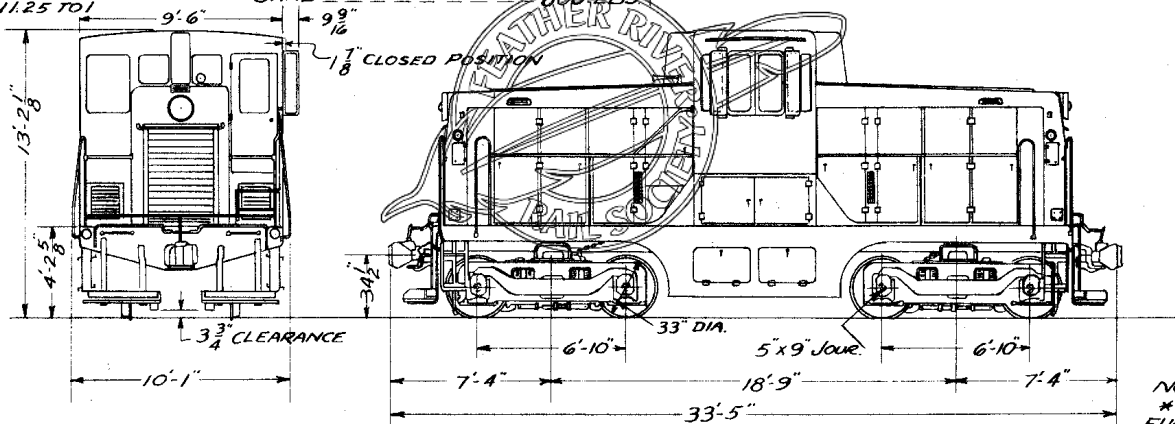

NOTE:  
 \* INCLUDES FULL LOAD  
 FUEL OIL, LUBR OIL, WATER,  
 SAND, ALL EQUIP. & 2 MEN.

RWC 4-24-58

S.N.R.Y. Nos. 301-A, 301-D No. of LOCOMOTIVES 2 **DIESEL-ELECTRIC FREIGHT 8-WHEEL**

**ROAD CLASS S.N. 301**  
**SYMBOL**

BUILT-ELECTRO-MOTIVE DIVN.-G.M.C. 1948

**POWER PLANT**

1-1500 H.P. GMC DIESEL ELECTRIC UNIT  
 DIESEL ENGINE 16-8 $\frac{1}{2}$ " x 10" CYLS. V TYPE,  
 2 CYCLE, MODEL 16-567-B

**MAIN GENERATOR**

1-EMD. TYPE D-12-14 NOM. VOLTAGE 600

**TRACTION MOTORS**

4 E.M.D. TYPE D-7-E VOLTAGE 600

**AIR COMPRESSOR**

1 GARDNER-DENVER TYPE WXE  
**BRAKE EQUIPMENT**  
 WESTINGHOUSE CLASP BRAKES  
 TYPE 24 RL

TRACTION POWER 59,000 LBS

MAX. TRACK CURVE 21°

MAX. PERMISSIBLE SPEED

65 MPH

MIN. CONTINUOUS RATING SPEED

7 M.P.H

**FUEL - DIESEL OIL**

**\*WEIGHTS IN WORKING ORDER**

TOTAL ON DRIVERS 236,500 LBS.

TOTAL DRY (LIGHT) WT. 213,970 LBS.

AXLE LOAD 59,125 LBS.

REV. 2-11-64  
 6-11-64  
 8-20-70

**GEAR RATIO**

LOCOMOTIVE S.N. 301-A 62:15

S.N. 301-D 62:15

FUEL DIESEL OIL 1200 GALS  
 LUBE OIL 200 "  
 ENG. COOLING WATER 230 "  
 TOILET 50 "  
 SAND 1600 LBS.

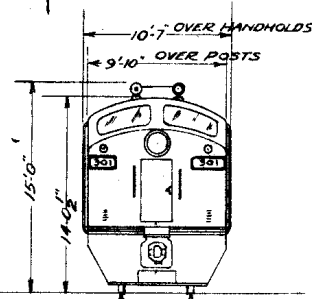
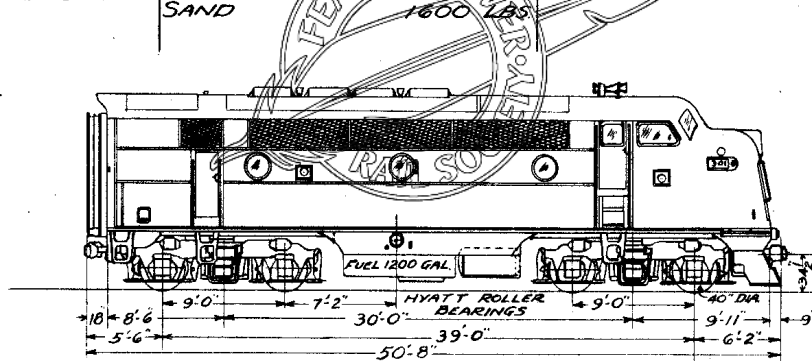

**NOTE:**  
 \* INCLUDES FULL LOAD OF FUEL OIL,  
 LUBE OIL, WATER, SAND, ALL EQUIPT.

RWC 4-30-58

NOS. S.N. 401-402 NO. OF LOCOS. 2  
 BUILT-ELECTRO-MOTIVE CORP. 1939  
 SPEC. NO. E.M.C. MODEL SW-1

# DIESEL SWITCHING 8-WHEEL

ROAD CLASS S.N. 401

SYMBOL S-50

FUEL-DIESEL OIL

POWER PLANT  
 1- 600 H.P. DIESEL ELECTRIC  
 ELECTRO-MOTIVE CORP.  
 DIESEL ENGINE MODEL 6-567  
 6-8 1/2 x 10" CYLS. V TYPE, 2 CYCLE

AIR COMPRESSOR  
 1- GARDNER-DENVER W.X.E.  
 BRAKE EQUIPT.  
 WESTINGHOUSE A.B. Co. 14 EL.

TRACTIVE POWER 50000 LBS.

\* WEIGHTS IN WORKING ORDER  
 ON DRIVERS OVER 20000 LBS. BY  
 LOCO. TOTAL ACTUAL SCALE WEIGHTS  
 PRESENT OFFICIAL WEIGHTS ON DRIVERS AND TOTAL  
 AFTER SAND BOXES ETC. HAVE BEEN REDUCED.

MAX. PERMISSIBLE SPEED 45 M.P.H.

MAX. TRACK CURVE 100 FT. RADIUS

AXLE LOAD 50000 LBS.

Loco. No.	20,310 LBS.	5-13-41
" "	19,960	6-23-41
" "	19,960	8-25-41

4-MOTORS ELECTRO-MOTIVE CORP.  
 TYPE DTA VOLTAGE 300-600

CONTROL EQUIPT.  
 ELECTRO-MOTIVE CORP.  
 VOLTAGE 64-76

GEAR RATIO 62:15

NOTE: THESE ENGINES WERE FORMERLY

W.P. NOS. 501 AND 502

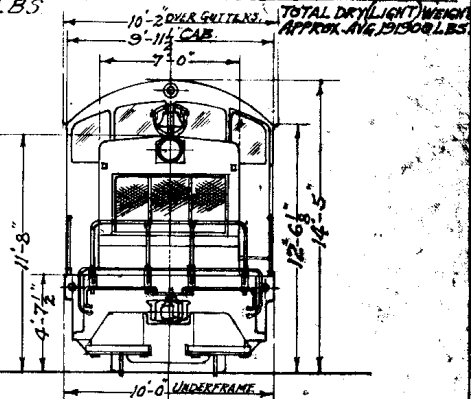
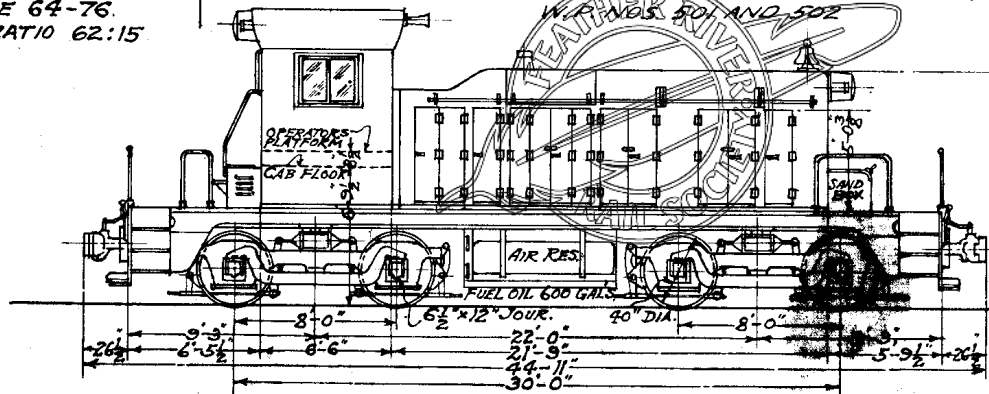

\* NOTE  
 INCLUDES FULL LOAD  
 FUEL, SAND, LUB. OIL, WATER, ALL EQUIPT.  
 AND 2 MEN IN CAB.

Nos. S.N. 403-404  
 DATE BUILT - No.403, 1945  
 - No.404, 1949

MODEL - ALCO S-2  
 POWER PLANT  
 1-1000 H.P. DIESEL ELECTRIC UNIT  
 DIESEL ENGINE A.L.Co. 539  
 6-12½"x13" CYLS. VERT., 4 CYCLE  
 GENERATORS  
 1-G.E. D.C. TYPE 553C  
 1-G.E. EXCITER, TYPE GMC. 139AC

## DIESEL-ELECTRIC SWITCHING 8-WHEEL

TRACTION MOTORS  
 4-G.E. D.C. TYPE 731  
 GEAR RATIO 75:16  
 CONTROL EQUIPMENT  
 G.E. TYPE P  
 AIR COMPRESSOR  
 1-WESTINGHOUSE TYPE 3-CD

BRAKE EQUIPMENT  
 WESTINGHOUSE EL-14  
 CLASP BRAKES  
 FUEL - DIESEL OIL ..... 635 GALS.  
 LUBE OIL ..... 80 "  
 ENGINE COOLING WATER. 240 "  
 SAND ..... 2700 LBS.

ROAD CLASS 403  
 SYMBOL S-57

WEIGHT IN WORKING ORDER  
 (INCL. FULL FUEL OIL, LUBE OIL,  
 WATER, SAND, EQUIPMENT &  
 CREW) - 230,000 LBS.

AXLE LOAD - 57,500 LBS.  
 TOTAL LIGHT WEIGHT - 220,100

TRACTION EFFORT - 57,500 LBS.  
 MAX. PERMISSIBLE SPEED 60MPH.  
 MAX. TRACK CURVE 50 FT. RADIUS

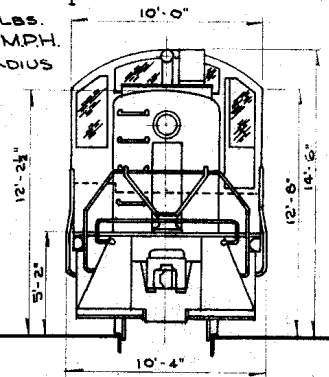
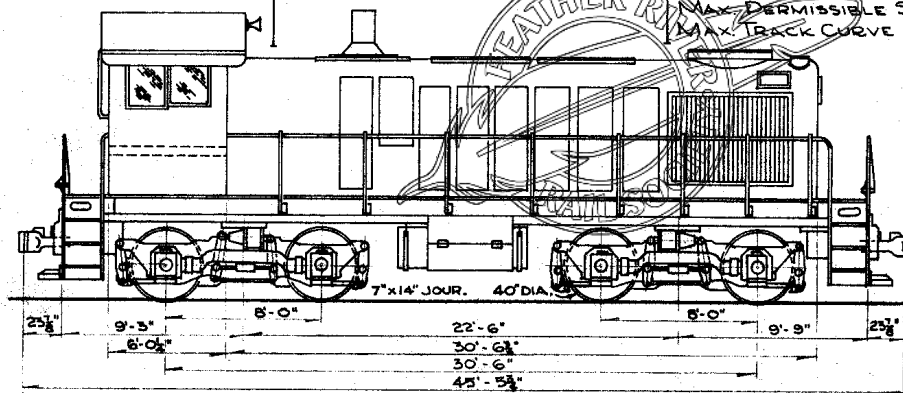

NO. 405 NO. OF LOCOS. 1

BUILT - ALCO. 1942

SPEC. NO. F-1530.

POWER PLANT

1-660 H.P. DIESEL-ELECTRIC UNIT.

DIESEL ENGINE A.L.CO.

6-12 1/2 x 19 CYLS. VERT. TYPE, 4 CYCLE

GENERATORS

1-G.E. DIRECT-CURRENT TYPE G.T. 552A

1-G.E. EXCITER TYPE G.M.G. 139-A1

TRACTION MOTORS

4-G.E. DIRECT-CURRENT TYPE G.E. T31

GEAR RATIO 75:16

CONTROL EQUIPMENT.

G.E. TYPE P.

# DIESEL-ELECTRIC SWITCHING 8-WHEEL

ROAD CLASS S.N. 405

SYMBOL - S-5

AFE 160-42

AIR COMPRESSOR

1- WESTINGHOUSE TYPE 3-CD

BRAKE EQUIPMENT

WESTINGHOUSE E.L-14

CLASP BRAKES

TRACTION POWER 50000 LBS.

MAX. PERMISSIBLE SPEED 60 M.P.H.

MAX. TRACK CURVE 50 FT. RADIUS

\* FUEL-DIESEL

WEIGHTS IN WORKING ORDER

TOTAL ON DRIVERS 202000

TOTAL DRY (LIGHT) WEIGHT 188000

AXLE LOAD 50500 LBS.

FUEL-DIESEL OIL ----- 635 GALS.

LUBR. ----- 80 "

ENGINE COOLING WATER 220 "

SAND ----- 2500 LBS.

NOTE: THIS ENGINE WAS

FORMERLY W.P. 504.

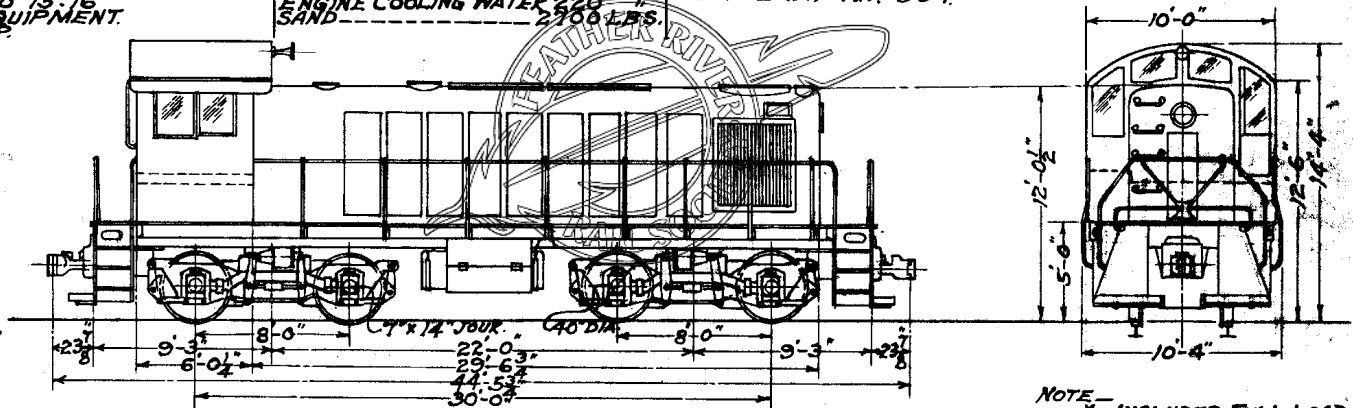

RWC 9-19-68

NOTE - \* INCLUDES FULL LOAD FUEL OIL, LUBR. OIL, WATER, SAND, ALL EQUIPT. AND 2 MEN.

No. S.N. 406  
 BUILT-ALCO. 1950  
 SPEC. NO. E-1540.

**POWER PLANT**  
 1-1000 H.P. DIESEL-ELECTRIC UNIT  
 DIESEL ENGINE A.L.CO.  
 6-TECH. C.I.S. VERT. TYPE, 4-CYCLE  
**GENERATORS**  
 1-G.E. DIRECT CURRENT TYPE G.T. 553A  
 1-G.E. EXCITER TYPE G.M.G. 139 A2  
**TRACTION MOTORS**  
 4-G.E. DIRECT CURRENT TYPE G.E. T31C  
 GEAR RATIO 15:16  
**CONTROL EQUIPMENT**  
 G.E. TYPE P.

# DIESEL-ELECTRIC SWITCHING 8-WHEEL

SYMBOL S50

**AIR COMPRESSOR**  
 1-WESTINGHOUSE TYPE 3-CD  
**BRAKE EQUIPMENT**  
 WESTINGHOUSE E.L.-14  
 CLASP BRAKES

**TRACTIVE POWER 57500 LBS.**  
**MAX. PERMISSIBLE SPEED 60 M.P.H.**  
**MAX. TRACK CURVE 50 FT. RADIUS.**

**FUEL-DIESEL OIL**  
**WEIGHT IN WORKING ORDER**  
**TOTAL ON DRIVERS 231000 LBS.**  
**TOTAL DRY (LIGHT) WEIGHT 221,200 LBS.**  
**AXLE LOAD 61,350 LBS.**

**FUEL-DIESEL OIL** ----- 635 GALS  
**LUBR.** ----- 80 "  
**ENGINE COOLING WATER** 2340 "  
**SAND** ----- 2500 LBS.

REV.  
 1-20-52  
 11-28-63  
 10-17-60  
 8-16-70

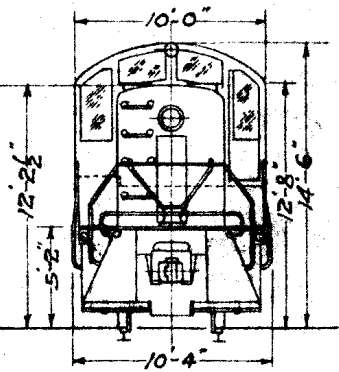
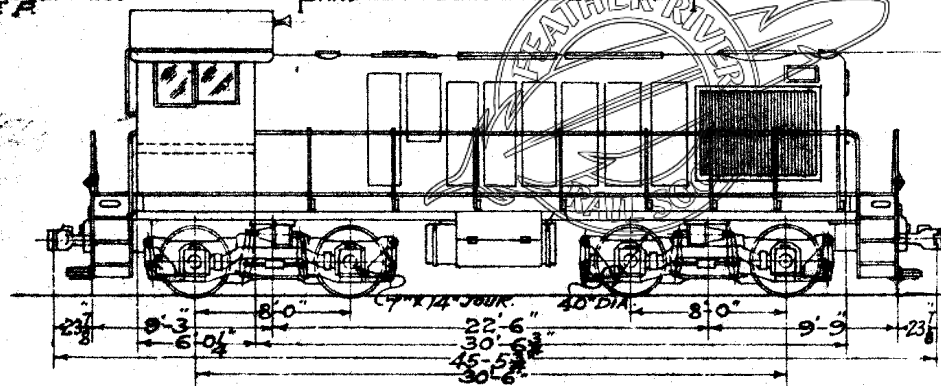

NOTE:  
 \* INCLUDES FULL LOAD FUEL  
 OIL, LUBR. OIL, WATER, SAND,  
 ALL EQUIP. AND 2-MEN.

R.J.D. 9-43

No. S.N. 407

BUILT 1945 - BALDWIN VO-1000

# DIESEL-ELECTRIC SWITCHING 8-WHEEL

SYMBOL S62

### POWER PLANT

1-1000 H.P. DIESEL-ELECTRIC UNIT

DIESEL ENGINE, BALDWIN DELAVERGNE

MODEL VP

8-12 1/2 x 15 1/2 CYLS. VERT. TYPE, 4-CYCLE

### GENERATORS

1-WESTINGHOUSE DIRECT-CURRENT

TYPE 480-B

1-WESTINGHOUSE EXCITER TYPE YG40-C

### TRACTION MOTORS

4-WESTINGHOUSE DIRECT-CURRENT TYPE 362-D

GEAR RATIO 65:14

### CONTROL EQUIPMENT

WESTINGHOUSE ELECTRO-PNEUMATIC

### AIR COMPRESSOR

1-GARDNER-DENVER TYPE WXO

### BRAKE EQUIPMENT

WESTINGHOUSE 6-DS

CLASP BRAKES

FUEL-DIESEL OIL --- 700 GALS

LUBR. --- 110

ENGINE COOLING WATER 290

SAND --- 3000 LBS.

TRACTIVE POWER 60000 LBS.

MAX. PERMISSIBLE SPEED 60 M.P.H.

MAX. TRACK CURVE 75 FT. RADIUS

\* FUEL-DIESEL OIL

WEIGHT IN WORKING ORDER

TOTAL ON DRIVERS 245400 LBS.

TOTAL DRY (LIGHT) WEIGHT 232400 LBS.

AXLE LOAD 61350 LBS.

REVISED:  
12-30-53  
12-15-60  
8-18-70

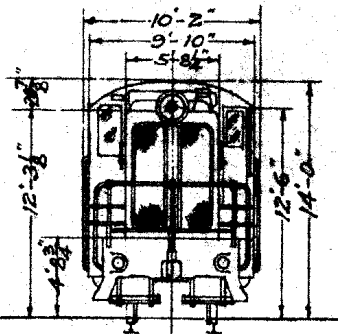
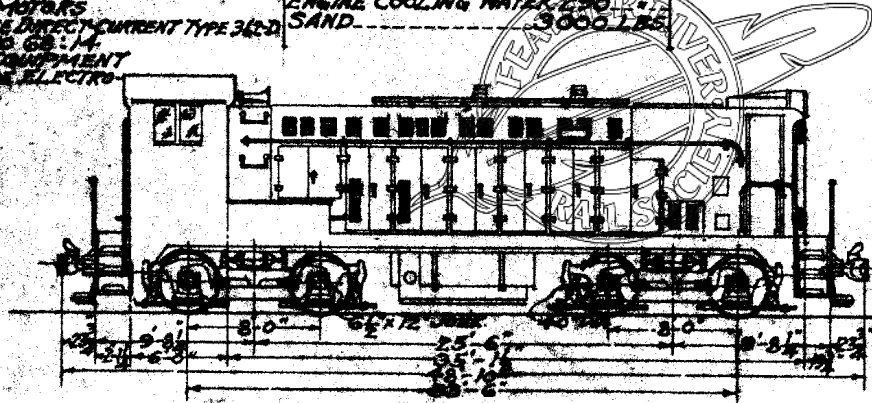

R.J.D. 2-4-46

NOTE - INCLUDES FULL LOAD  
\* FUEL OIL, LUBR. OIL, WATER, SAND,  
ALL EQUIPT. AND 2-MEN.



BOX CAR, CLASS XM  
 BUILT BY MT. VERNON CAR MFG. CO.  
 1917-18

CAR NOS. S.N. 2301-2327

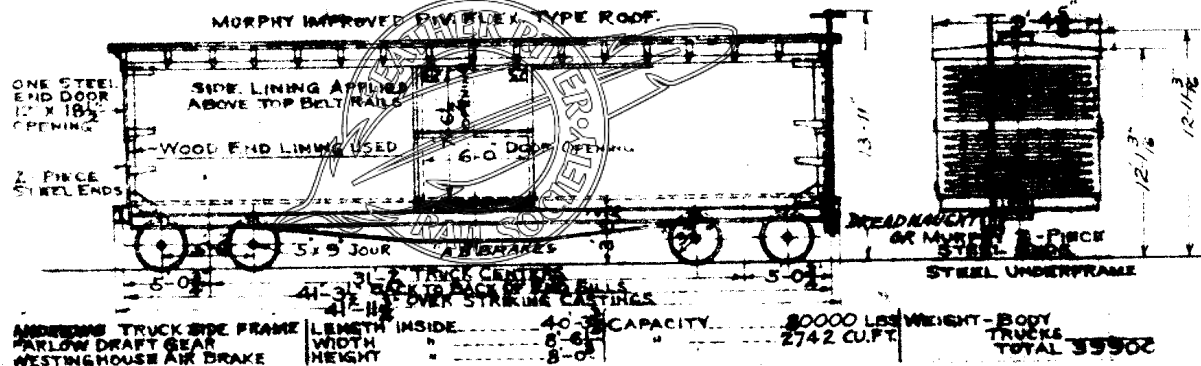

BOX CAR, CLASS XM  
 BUILT BY MT. VERNON CAR MFG. CO.

CAR NOS S.N. 2329-2350

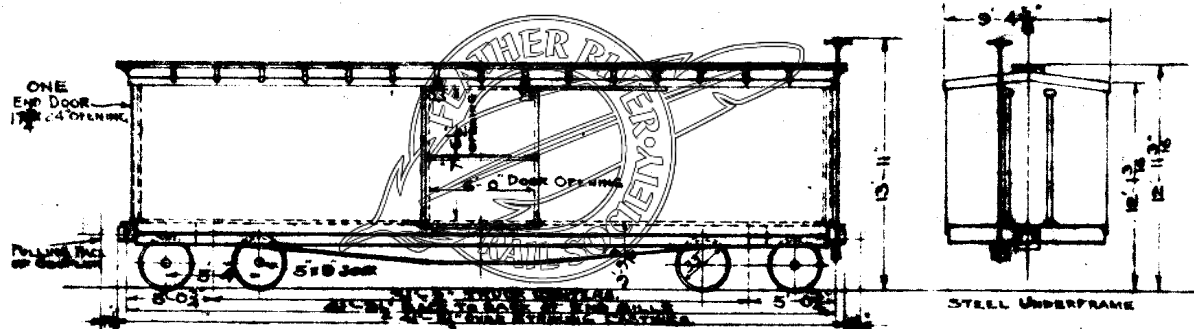

ANDREWS TRUCK SIDE FRAME  
 FARLOW DRAFT GEAR  
 WESTINGHOUSE AIR BRAKE

LENGTH INSIDE 40'-0"  
 WEIGHT " 8'-0"

CAPACITY 80000 LBS.  
 2730 CU. FT.

WEIGHT-BODY  
 TRUCKS  
 TOTAL 39400 LBS

BUILDERS LOT NO. 8268-B

BOX CAR, CLASS XM  
BUILT BY PULLMAN STANDARD CAR MFG. CO.  
AFE S.N. 27-55

CAR NOS. S.N. 2401-2500  
ORIG. NO. OF CARS 100

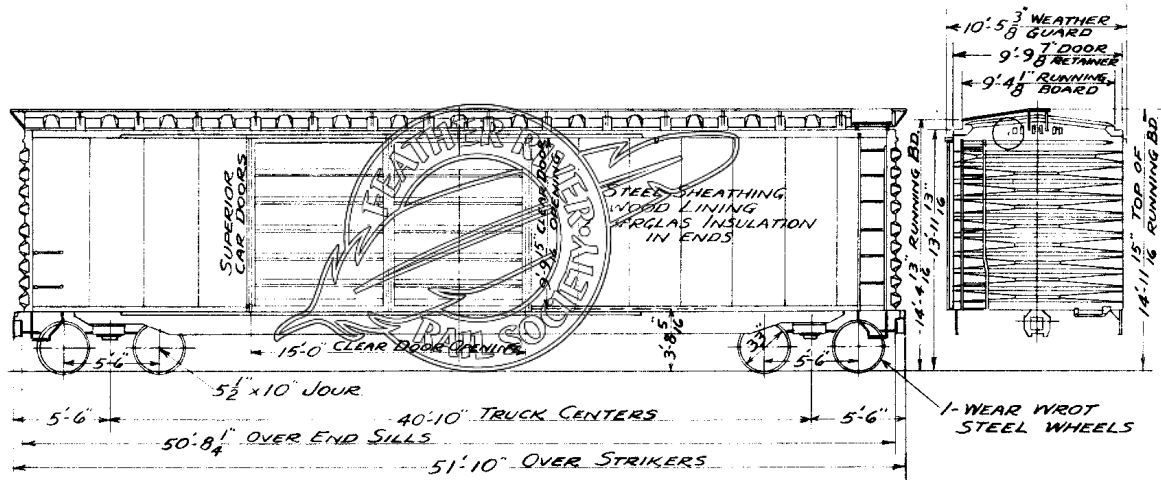

BARBER S-2-C STABILIZED TRUCKS  
RUBBER DRAFT GEARS  
WESTINGHOUSE TYPE AB1012 AIR BRAKES

LENGTH INSIDE --- 50'-5 9/16"  
WIDTH " --- 9'-2 1/16"  
HEIGHT " --- 10'-5 1/2"

CAPACITY --- 100000 LBS.  
" --- 4840 CU. FT.

WEIGHT - BODY  
TRUCKS  
TOTAL 55800 LBS.

BUILDERS JOB No. 459-A

ALL STEEL SINGLE SHEATHED BOX CAR, CLASS XP  
 BUILT BY THRALL CAR MFG. Co. FEB. 1969  
 AFE SN 5-69

CAR Nos. SN 3735-3736  
 No. OF CARS 2

EQUIPPED WITH FREIGHTMASTER  
 TYPE "HDFRB" CUSHIONING DEVICE, 15" TRAVEL  
 & EQUIPCO 1 PC. LOAD DIVIDERS

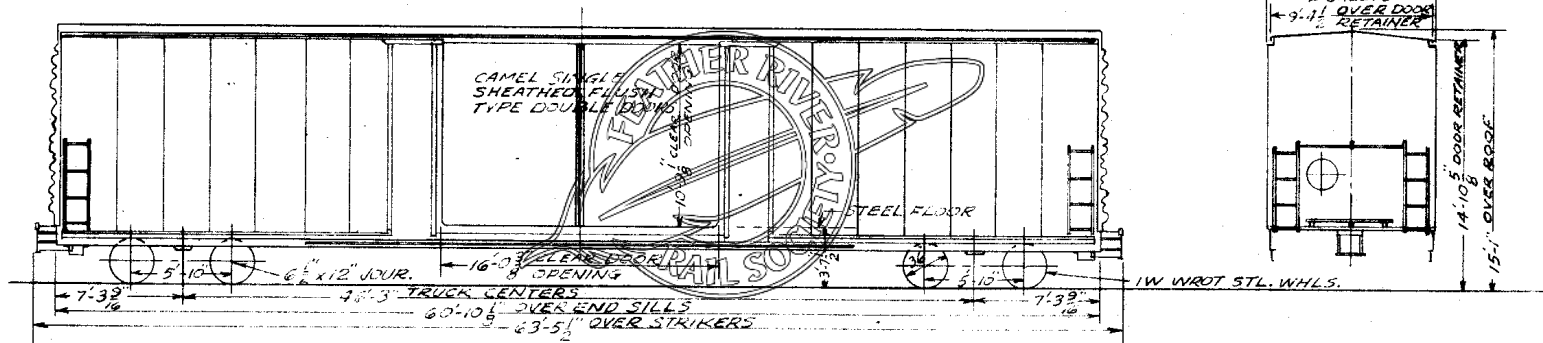

COMPOSITION BRAKE SHOES  
 BARBER S2C STABILIZED TRUCKS  
 TIMKEN AP ROLLER BEARINGS

LENGTH INSIDE 60'-9"  
 WIDTH " 9'-1 3/4"  
 HEIGHT " 10'-9"

CAPACITY 163,000 LBS.  
 " 6000 CU.FT.

WEIGHT-BODY 78,400  
 TRUCKS 20,400  
 TOTAL 98,800

RWC 7-25-69

BUILDERS ORDER NO. 45091

ALL STEEL SINGLE SHEATHED BOX CARS, CLASS XP

CAR NOS SN 3737

BUILT BY MAXSON CORP FEB. 1970

NO OF CARS - 1

AFE: SN 24-69

NYCOPAC BRAKES - COMPOSITION SHOES  
KEYSTONE CUSHION UNDERFRAME - 20 TRAVEL

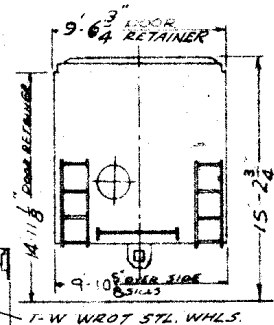
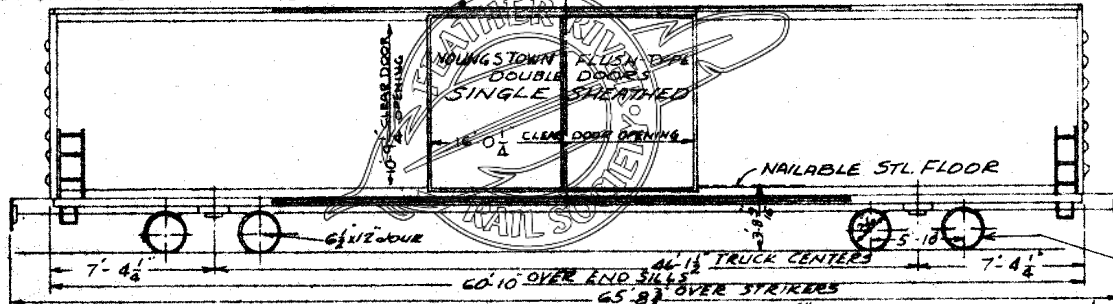

ASF RIDE CONTROL A-3 TRUCKS  
WESTINGHOUSE NY11F DRAFT GEAR  
BRENCO ROLLER BEARINGS

LENGTH INSIDE 60'-9 1/2"  
WIDTH " 9'-2"  
HEIGHT " 11'-2 1/8"

CAPACITY 173,000 LBS  
6250 CU. FT.

WEIGHT BODY 68,100  
" TRUCKS 20,400  
TOTAL 88,500 LBS.

BUILDERS LOT NO. 01-5124

DROP BOTTOM GONDOLA, CLASS GS  
BUILT BY AMERICAN CAR & FOUNDRY CO.  
AFE SN. 16-57

CAR NOS. S.N. 4001-4020  
ORIG. NO. OF CARS 20

ALL CARS EQUIPPED WITH  
LUBRICATOR PADS.

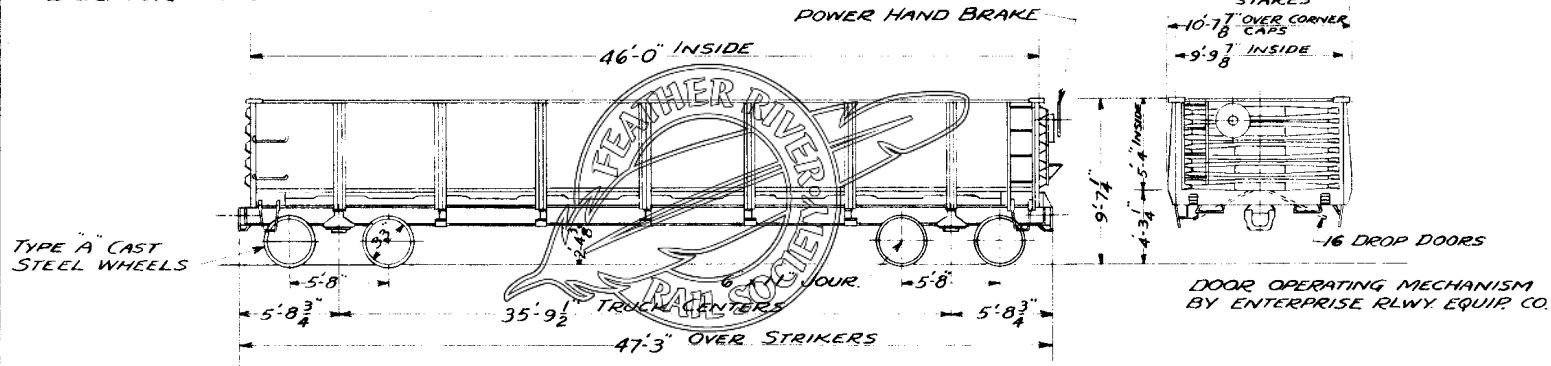

ASF A-3 RIDE CONTROL TRUCKS  
CARDWELL-WEST NY-11-F DRAFT GEAR  
WESTINGHOUSE TYPE AB 1012 AIR BRAKES

LENGTH INSIDE	46'-0"
WIDTH	9'-9 7/8"
HEIGHT	5'-4"

CAPACITY	140000 LBS
	2410 CUFT
	LEVEL FULL

WEIGHT - BODY TRUCKS	TOTAL 56300 LBS
----------------------	-----------------

RWC 4-23-58

REV:  
5-22-68

BUILDERS LOT 5363

GONDOLA CARS, CLASS GB  
BUILT BY AMERICAN CAR & FDRY. JULY 1959  
AFE S.N. 4-59

CAR NOS. S.N. 4501-4525  
NO. OF CARS 25

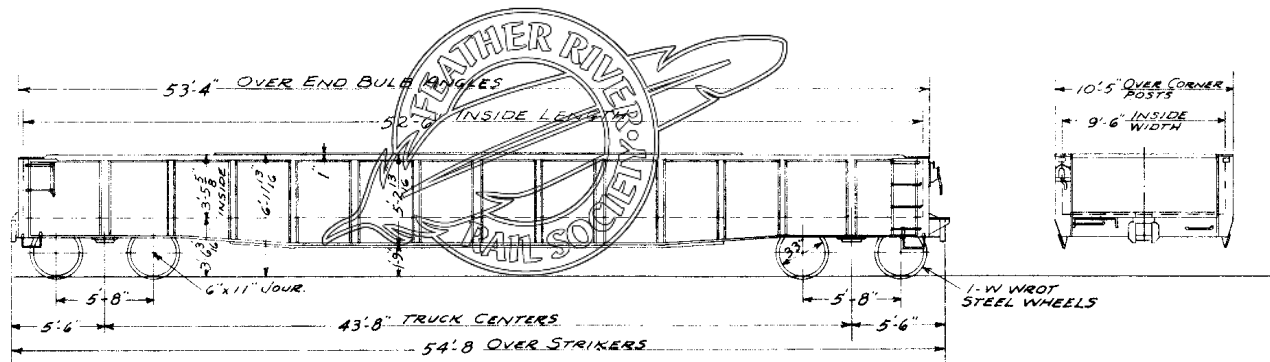

BARBER S-2-A STABILIZED TRUCKS  
MINER A-22-XL DRAFT GEARS  
ROLLER BEARINGS

LENGTH INSIDE	52'-6"
WIDTH	9'-6"
HEIGHT	3'-5 <sup>1</sup> / <sub>2</sub> "

CAPACITY	140,000 LBS.
	1728 CUFT.

WEIGHT-BODY	39590
TRUCKS	16440
TOTAL	56030 LBS.

RWC 3-8-60

BUILDERS LOT NO. 11-5259

COVERED HOPPER CAR, CLASS LO  
BUILT BY AMERICAN CAR & FOUNDRY CO.

CAR NOS. S.N. 5001-5010  
ORIG. NO. OF CARS 10

ALL CARS EQUIPPED  
WITH LUBRICATOR PADS.

AFE S.N. 2-59

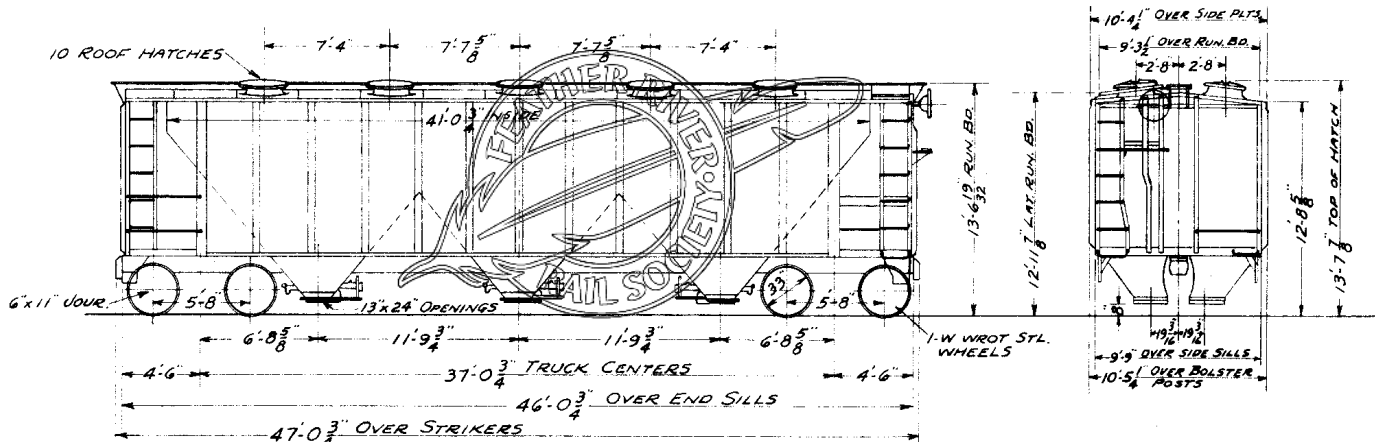

ENTERPRISE PNEUMATIC OUTLETS  
TRUCKS, ASF A-3 RIDE CONTROL  
DRAFT GEAR, AAR APPROVED  
AIR BRAKES, WESTINGHOUSE TYPE AB-1012

LENGTH INSIDE 41'-0<sup>3</sup>/<sub>4</sub>"  
WIDTH " 9'-9"

CAPACITY 140,000 LBS.  
3200 CU.FT.

WEIGHT-BODY 47210  
TRUCKS 16440  
TOTAL 63650 LB.

RWC 11-3-58



BUILDERS LOT 8460-G

COVERED HOPPER CARS, CLASS LO  
 BUILT BY PULLMAN STANDARD MAY 1959  
 AFE S.N. 4-59

CAR NOS S.N. 5011-5020  
 NO. OF CARS 10

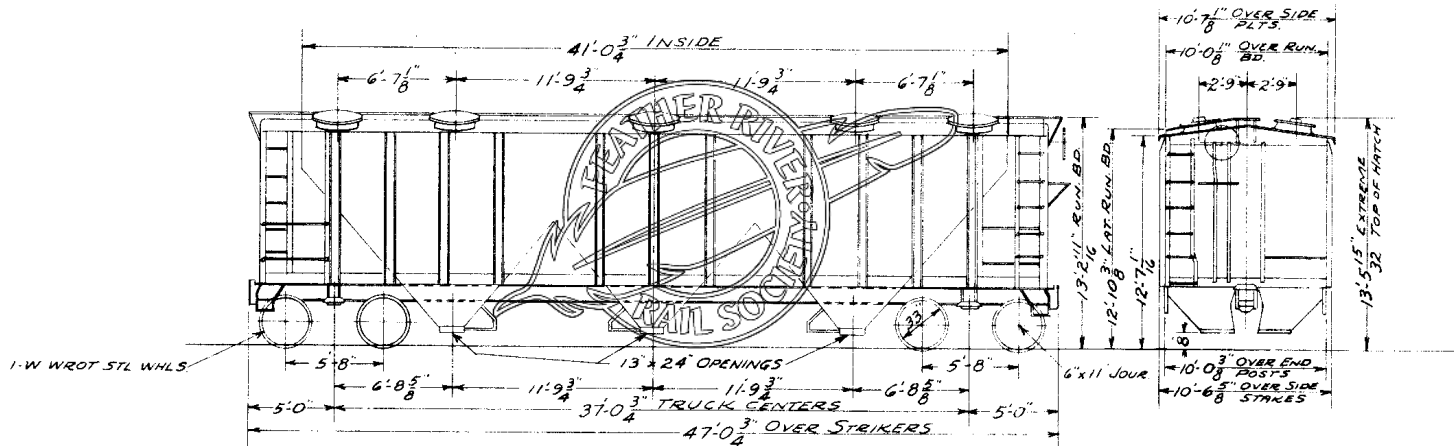

ENTERPRISE PNEUMATIC OUTLETS  
 ASF A-3 RIDE CONTROL TRUCKS  
 WAUGH NO. 420 DRAFT GEARS  
 TIMKEN AP ROLLER BEARINGS

RWC 3-10-60

LENGTH INSIDE  
 WIDTH "

41'-0<sup>3</sup>/<sub>4</sub>"  
 9'-11<sup>1</sup>/<sub>8</sub>"

CAPACITY  
 "

140,000 LBS  
 3219 CU.FT.

WEIGHT-BODY 46260  
 TRUCKS 16440

TOTAL 62700 LBS

BUILDERS LOT 11-5389-E

COVERED HOPPER CARS, CLASS L0  
 BUILT BY AMERICAN CAR & FOUNDRY MARCH 1960  
 AFE S.N. 12-60

CAR NOS. S. N. 5101-5110  
 NO. OF CARS 10

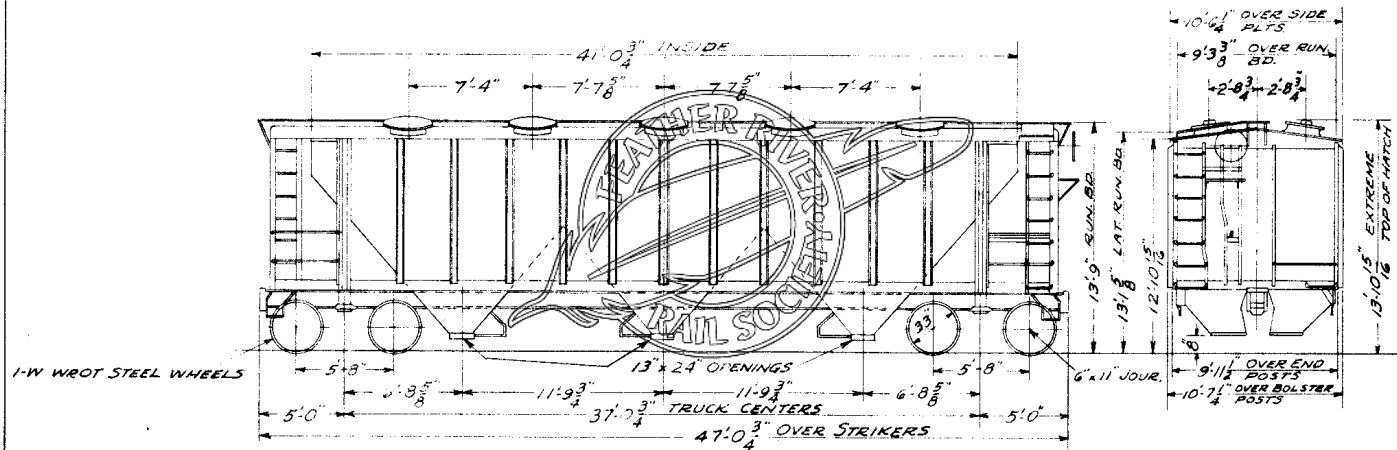

KEYSTONE OUTLET GATES  
 ASF A-3 RIDE CONTROL TRUCKS  
 DRAFT GEAR AAR APPROVED  
 TIMKEN AP ROLLER BEARINGS

RWC 4-6-60

LENGTH INSIDE  
 WIDTH "

41'0 <sup>3</sup>/<sub>4</sub>"  
 9'-11"

CAPACITY

140,000 LBS.  
 3500 CU.FT.

WEIGHT-BODY 45760  
 TRUCKS 16440  
 TOTAL 62200



INSULATED BOX CARS, CLASS RBL  
 BUILT BY THRALL CAR MFG. CO. DEC. 1961

CAR NOS S.N. 8001-8040  
 NO. OF CARS 40

AFE S.N. 28-61

REV. 4-22-63

S.N.	CAR PAC LOADERS	LENGTH OF TRAVEL & TYPE OF CUSHION UNDERFRAME	ROLLER BEARINGS	WEIGHT	DISTANCE OVER STRIKERS	DRAFT GEARS
8001-8005	4 BELT	24"-NATIONAL	SKF	74800	56'-5 <sup>3</sup> / <sub>16</sub> "	NAT'L CSTGS MS-430
8006-8010	6 BELT	24"-NATIONAL	SKF	75400	"	NAT'L CSTGS MS-430
8011-8032	6 BELT	20"-KEYSTONE	TIMKEN	75600	55'-7 <sup>1</sup> / <sub>16</sub> "	MINER A-22-XL
8033-8040	6 BELT	20"-KEYSTONE	HYATT	75600	"	MINER A-22-XL

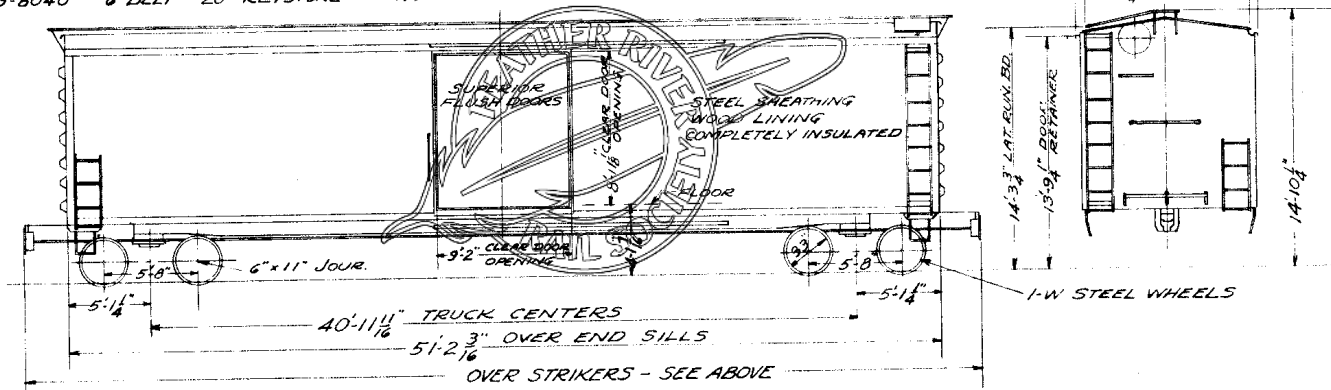

ASF A-3 RIDE CONTROL TRUCKS  
 DRAFT GEARS - SEE ABOVE  
 ROLLER BEARINGS - SEE ABOVE

LENGTH INSIDE 50'-6"  
 WIDTH " 9'-4"  
 HEIGHT " 9'-6"

CAPACITY  
 " " " " " "

133000 LBS WEIGHT-BODY  
 4477 CUFT TRUCKS 16440  
 TOTAL SEE ABOVE