

LOCOMOTIVE & FREIGHT  
EQUIPMENT

SACRAMENTO NORTHERN RAILWAY  
AND

TIDEWATER SOUTHERN RAILWAY

*LOCOMOTIVE & FREIGHT  
EQUIPMENT*

*TIDEWATER SOUTHERN RAILWAY*

Nos. T.S. 744 -745  
 DATE BUILT - No. 744, 1948  
 - No. 745, 1949

MODEL - ALCO S-2

POWER PLANT

1-1000 H.P. DIESEL ELECTRIC UNIT  
 DIESEL ENGINE A.L.Co. 539  
 6-12½"x13" CYLS. VERT., 4 CYCLE

GENERATORS

1-G.E. D.C. TYPE 553C  
 1-G.E. EXCITER, TYPE GMC. 139AC

## DIESEL-ELECTRIC SWITCHING 8-WHEEL

TRACTION MOTORS

4-G.E. D.C. TYPE 731  
 GEAR RATIO 75:16

CONTROL EQUIPMENT

G.E. TYPE P

AIR COMPRESSOR

1-WESTINGHOUSE TYPE 3-CD

BRAKE EQUIPMENT

WESTINGHOUSE EL-14

CLASP BRAKES

FUEL - DIESEL OIL ..... 635 GALS.

LUBE OIL ..... 80 "

ENGINE COOLING WATER 240 "

SAND ..... 2700 LBS.

TRACTION EFFORT - 57,500 LBS.

MAX. PERMISSIBLE SPEED 60 M.P.H.

MAX. TRACK CURVE 50 FT. RADIUS

ROAD CLASS 744

SYMBOL S-57

WEIGHT IN WORKING ORDER  
 (INCL. FULL FUEL OIL, LUBE OIL,  
 WATER, SAND, EQUIPMENT &  
 CREW) - 230,000 LBS.

AXLE LOAD - 57,500 LBS.

TOTAL LIGHT WEIGHT. 220,100

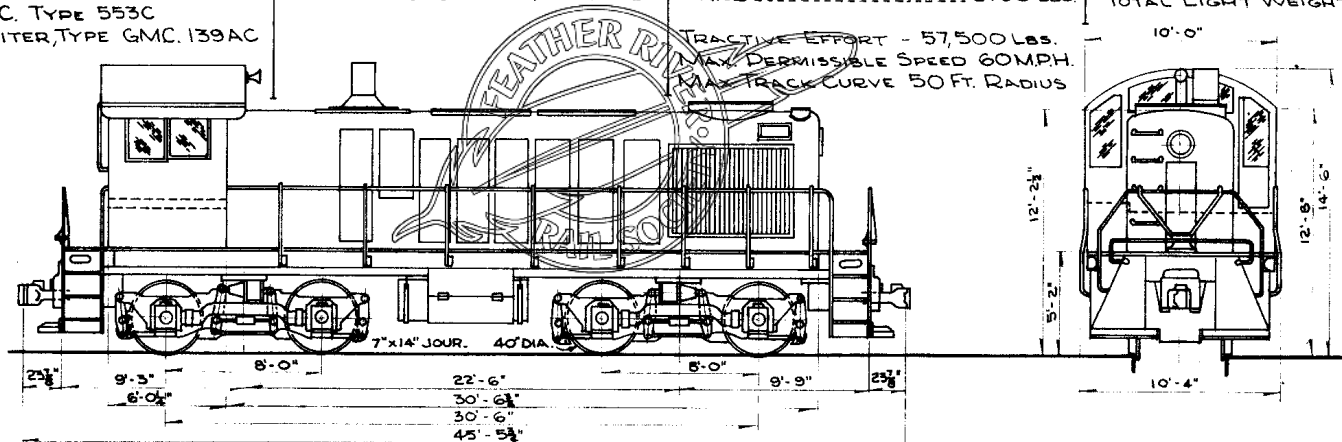

BUILDERS LOT NO 01-5124

DROP BOTTOM GONDOLA, CLASS GS  
BUILT BY AMERICAN CAR & FOUNDRY CO.  
AFE T.S. 5-57

CAR NOS T.S. 201-205  
ORIG. NO. OF CARS 5

ALL CARS EQUIPPED WITH  
LUBRICATOR PADS

POWER HAND BRAKE

-10'-8" OVER SIDE  
STAKES  
-10'-7" OVER CORNER  
-9'-9" INSIDE

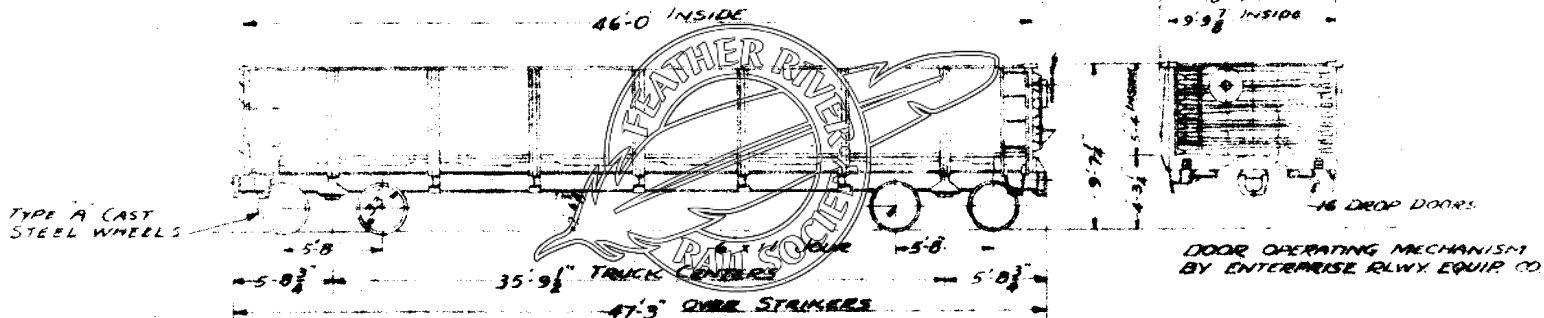

ASF A-3 RIDE CONTROL TRUCKS  
CARDWELL-WEST NY-11 F DRAFT GEAR  
WESTINGHOUSE TYPE AD 1012 AIR BRAKES

LENGTH INSIDE 46'-0"  
WIDTH " 9'-9 1/2"  
HEIGHT " 5'-8"

CAPACITY 110000 LBS  
2410 CU FT  
LEVEL FULL

WEIGHT - BODY  
TRUCKS  
TOTAL 56300 LBS

RWC 8-23-58

BUILDERS LOT NO. 8240

BOX CAR, CLASS XM  
 BUILT BY PULLMAN STANDARD CAR MFG. CO.  
 AFE T.S. 23-55.

CAR NOS. T.S. 501-525  
 ORIG. NO. OF CARS 25.

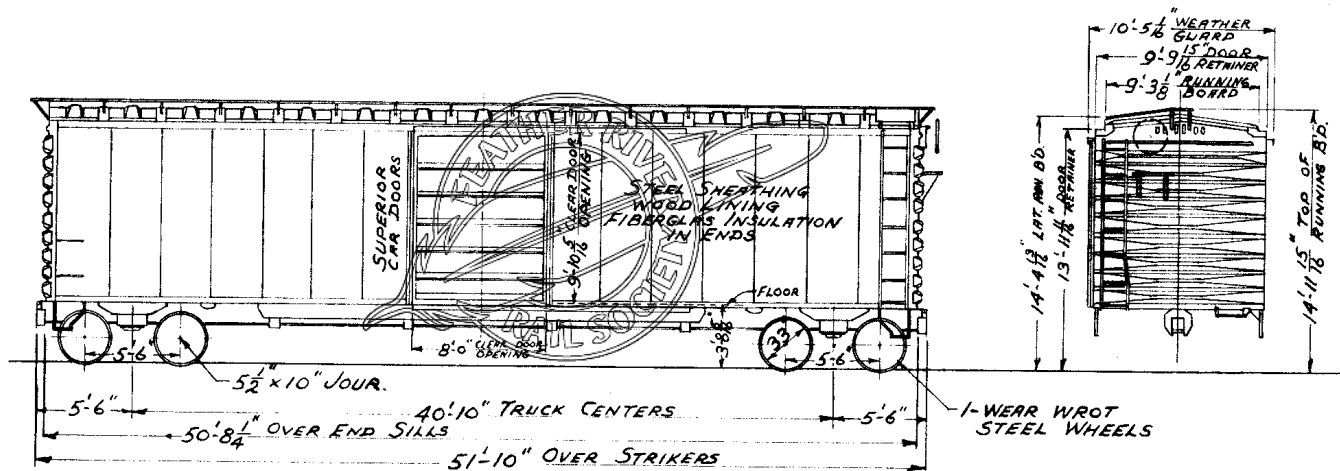

SCULLIN A-3 RIDE CONTROL TRUCKS  
 N.M. & S.C. CO. TYPE MF-275 RUBBER DR. GEAR  
 WESTINGHOUSE TYPE AB-1012 AIR BRAKES

LENGTH INSIDE --- 50'-5<sup>9</sup>/<sub>16</sub>"  
 WIDTH " --- 9'-2<sup>1</sup>/<sub>16</sub>"  
 HEIGHT " --- 10'-5<sup>1</sup>/<sub>2</sub>"

CAPACITY --- 100000 LBS.  
 " --- 4844 CU. FT.

WEIGHT - BODY  
 TRUCKS  
 TOTAL 52000 LBS

BUILDERS LOT No WP-57.

INSULATED BOX CAR, CLASS RBL  
 BUILT BY PACIFIC CAR & FOUNDRY CO.  
 AFE T.S. 17-57.

CAR NOS. T.S. 601 - 610  
 ORIG. No. OF CARS 10

TS 601-605, 1 WEAR WROT STL. WHEELS  
 TS 606-610, TYPE "A" CAST STL. WHEELS  
 CARS EQUIPPED WITH PC LOADERS:  
 TS 601-608, 8 BELTS  
 TS 609-610, 6 BELTS.

601-605 606-610  
 ROLLER BEARINGS HYATT TIMKEN  
 DRAFT GEAR FR-16 MF-400

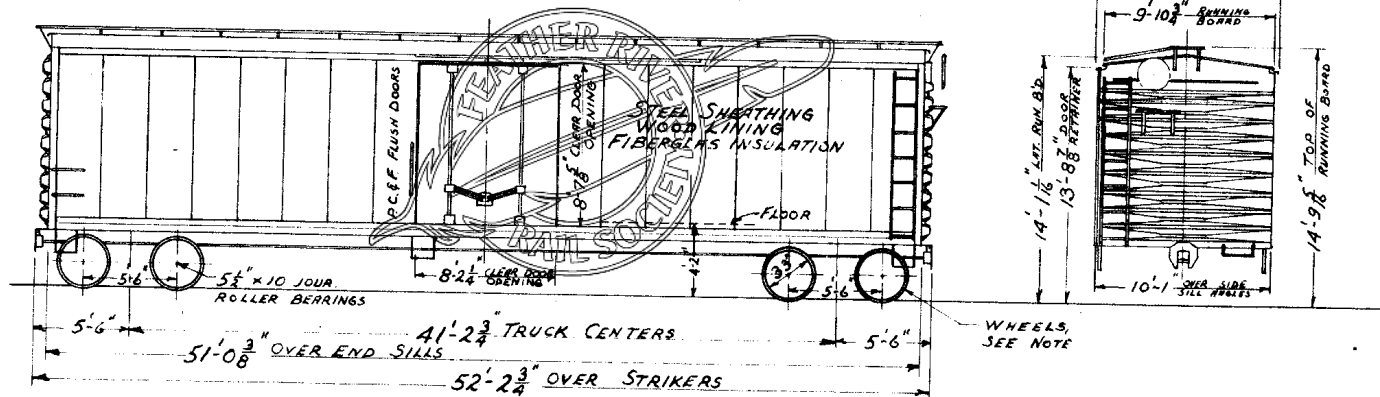

BARBER STABILIZED, TYPE S-2-C TRUCKS RUBBER DRAFT GEAR-SEE TABLE WESTINGHOUSE TYPE AB-1012 AIR BRAKES HHL 5-2-58.	LENGTH INSIDE	50'-0"	CAPACITY	97000 LBS.	WEIGHT - BODY
	WIDTH	9'-2"	"	4154 CU.FT.	TRUCKS
	HEIGHT	9'-1"	"		TOTAL 70900 LBS

BUILDERS LOT NO WP-58

INSULATED BOX CARS, CLASS RBL  
 BUILT BY PACIFIC CAR & FOUNDRY DEC. 1958  
 AFE T.S. 2-59

CAR NOS. T.S. 611-620  
 T.S. 801-840  
 NO OF CARS 50

NOTE:  
 TS 611-620 EQUIPPED WITH 6 BELT PC LOADERS - WIDTH INSIDE 9'-2" - TOTAL WT. 70200 LBS.  
 TS 801-840 EQUIPPED WITH 8 BELT DF LOADERS - WIDTH INSIDE 9'-1<sup>3</sup>/<sub>4</sub>" - TOTAL WT. 71400 LBS.

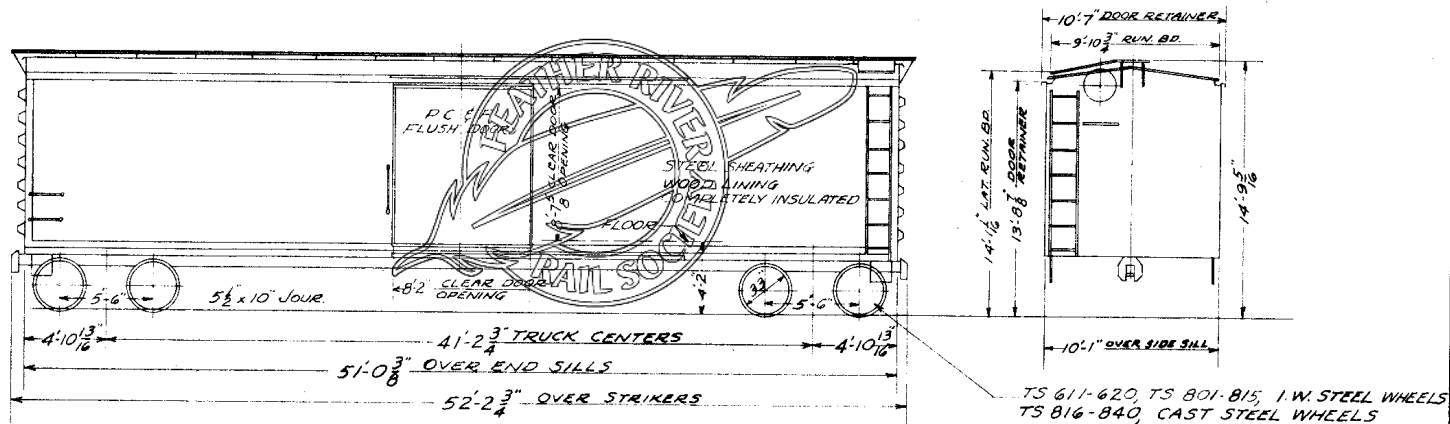

BARBER S-2-C STABILIZED TRUCKS	LENGTH INSIDE	50'-6"	CAPACITY	97000 LBS.	WEIGHT BODY
N.M. & S.C. Co. MF-400 RUBBER DRAFT GEAR	WIDTH	SEE NOTE	"	4154 CU. FT.	TRUCKS 14590
AAR FRICTION BEARINGS	HEIGHT	9'-1"	"		TOTAL SEE NOTE

RWC 10-6-60

LOCOMOTIVE & FREIGHT  
EQUIPMENT  
SACRAMENTO NORTHERN RAILWAY

SACRAMENTO NORTHERN



SN.RY. Nos. 142-147 No. of LOCO'S 6

BUILT-GEN. ELEC. CO.

LOCO'S 142-146, 1946

LOCO. 147, 1942

POWER PLANT

2-190 H.P. CATERPILLAR DIESEL

ENGINES TYPE D-17000

8-5 1/2 x 8" CYLS. "V" TYPE, 4 CYCLE

GENERATORS

2-G.E. DIRECT CURRENT TYPE GT-555

2-G.E. EXCITER TYPE G.M.G.-140

TRACTION MOTORS

4 G.E. DIRECT CURRENT TYPE G.E.-733

GEAR RATIO 11.25 TO 1

# DIESEL-ELECTRIC SWITCHING 8-WHEEL ROAD CLASS SN-142

SYMBOL S-26

FUEL-DIESEL OIL

\* WEIGHTS IN WORKING ORDER

TOTAL ON DRIVERS 88,000 LBS.

TOTAL DRY (LIGHT) WT. 84,900 LBS.

AXLE LOAD 22,000 LBS.

AIR COMPRESSOR

2 GARDNER-DENVER TYPE ADS.

BRAKE EQUIPMENT

WESTINGHOUSE A.B. Co. STRAIGHT

AND AUTOMATIC SCHEDULE 14-EL

TRACTIVE POWER 26,400 LBS.

MAX. PERMISSIBLE SPEED 35 MPH.

MAX. TRACK CURVE 50 FT. RADIUS

FUEL-DIESEL OIL ----- 250 GALS.

LUBR. ----- 100 GALS.

ENGINE COOLING WATER ----- 80 GALS.

SAND ----- 800 LBS.

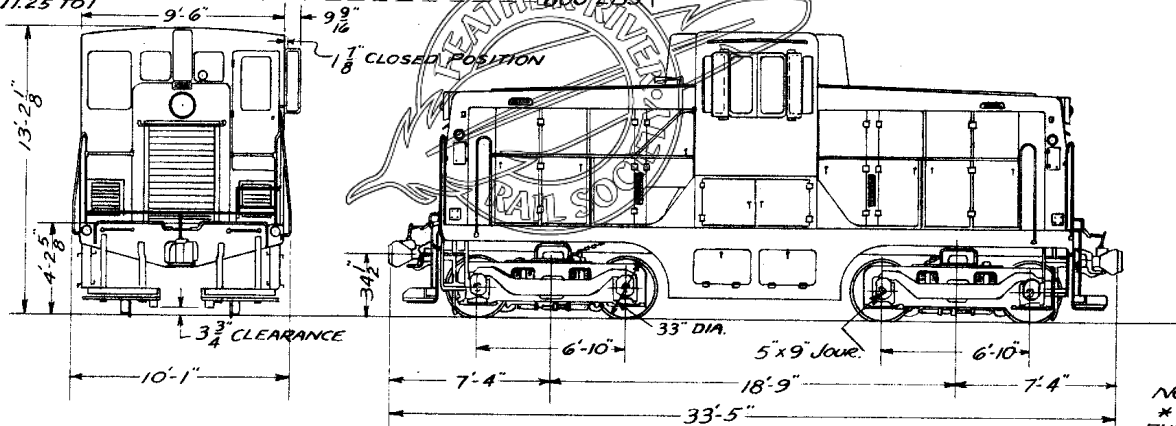

NOTE:

\* INCLUDES FULL LOAD  
FUEL OIL, LUBR OIL, WATER,  
SAND, ALL EQUIP. & 2 MEN.

RWC 4-24-58

S.N.R.Y. Nos. 301-A, 301-D No. of LOCO'S 2  
 W.P.R.R. No. 801-D No. of LOCO'S 1

# DIESEL-ELECTRIC FREIGHT 8-WHEEL

ROAD CLASS SN.301  
 SYMBOL

BUILT-ELECTRO-MOTIVE DIVN.-G.M.C. 1948

**POWER PLANT**

1-1500 H.P. GMC DIESEL ELECTRIC UNIT  
 DIESEL ENGINE 16-8 $\frac{1}{2}$ "x10" CYLS V TYPE,  
 2 CYCLE, MODEL 16-567-B

**MAIN GENERATOR**

1-EMD. TYPE D-12-14 NOM. VOLTAGE 600

**TRACTION MOTORS**

LOCO'S S.N. 301-302  
 4 E.M.D. TYPE D-7-E VOLTAGE 600

LOCO. W.P. 801-D

4 E.M.D. TYPE D-27-B VOLTAGE 600

**GEAR RATIO**

LOCO'S S.N. 301-A 62:15  
 S.N. 301-D 65:12  
 LOCO. WP 801-D 62:15

**AIR COMPRESSOR**  
 1 GARDNER-DENVER TYPE WXE  
**BRAKE EQUIPMENT**  
 WESTINGHOUSE CLASP BRAKES  
 TYPE 24 RL

FUEL DIESEL OIL \*\*1200 GALS  
 LUBE OIL 200 "  
 ENG. COOLING WATER 230 "  
 TOILET 50 "  
 SAND 1600 LBS

\*\* EXCEPT 801-D, 1500 GALS.

TRACTION POWER 59,000 LBS

MAX. TRACK CURVE 21°

MAX. PERMISSIBLE SPEED

LOCO'S S.N. 301-302 50 M.P.H.  
 LOCO. W.P. 801-D 65 M.P.H.

MIN. CONTINUOUS RATING SPEED

11 M.P.H

FUEL - DIESEL OIL  
 \* WEIGHTS IN WORKING ORDER  
 TOTAL ON DRIVERS 236,500 LBS.  
 TOTAL DRY (LIGHT) WT. 213,970 LBS.  
 AXLE LOAD 59,125 LBS.

REV. 2-11-64  
 6-11-64

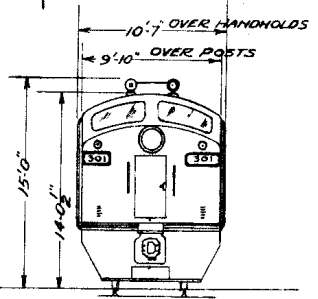
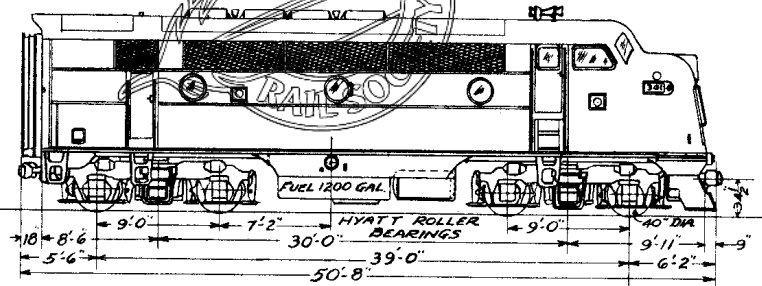

NOTE:  
 \* INCLUDES FULL LOAD OF FUEL OIL,  
 LUBE OIL, WATER, SAND, ALL EQUIPT.

RWC 4-30-58

S N 401 & 402

NOS. 501-503 NO. OF LOCOS. 3  
 BUILT-ELECTRO-MOTIVE CORP. 1939  
 SPEC. NO. E.M.C. MODEL SW-1

# DIESEL SWITCHING 8-WHEEL

ROAD CLASS 501  
 SYMBOL S-50  
 FUEL-DIESEL OIL

POWER PLANT  
 1- 600 H.P. DIESEL ELECTRIC  
 ELECTRO-MOTIVE CORP.  
 DIESEL ENGINE MODEL G-567  
 6-8 1/2" x 10" CYLS. V TYPE, 2 CYCLE  
 4-MOTORS, ELECTRO-MOTIVE CORP.  
 TYPE D7A VOLTAGE 300-600

AIR COMPRESSOR  
 1- GARDNER-DENVER W.X.E.  
 BRAKE EQUIPT.  
 WESTINGHOUSE A.B. Co. 14 EL.

TRACTIVE POWER 50000 LBS.  
 MAX. PERMISSIBLE SPEED 45 M.P.H.  
 MAX. TRACK CURVE 100 FT. RADIUS.  
 AXLE LOAD 50000 LBS.

\* WEIGHTS IN WORKING ORDER.  
 ON DRIVERS OVER 200000 LBS. BY  
 LOCO. TOTAL ACTUAL SCALE WEIGHTS  
 PRESENT OFFICIAL SCALE WEIGHTS ON DRIVERS AND TOTAL  
 AFTER SAND BOXES ETC. HAVE BEEN REDUCED.

Loco. No.	501	283,140 LBS.	5-13-41
"	502	199,630 "	6-23-41
"	503	199,380 "	8-23-41

CONTROL EQUIPT.  
 ELECTRO-MOTIVE CORP.  
 VOLTAGE 64-76  
 GEAR RATIO 62:15

NOTE:  
 UNITS 401 AND 402 SOLD TO S.N.R.V. IN 1966  
 AND REPLACED SINCE 401 AND 402 INCL.

REVISED  
 12-15-60  
 5-16-67

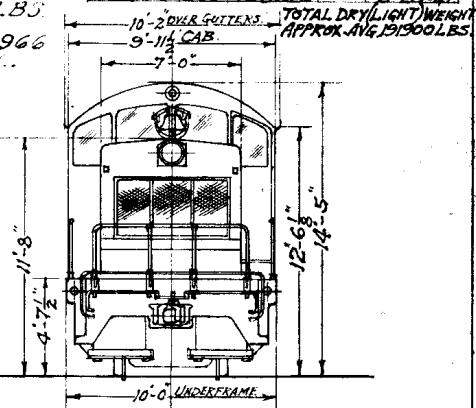
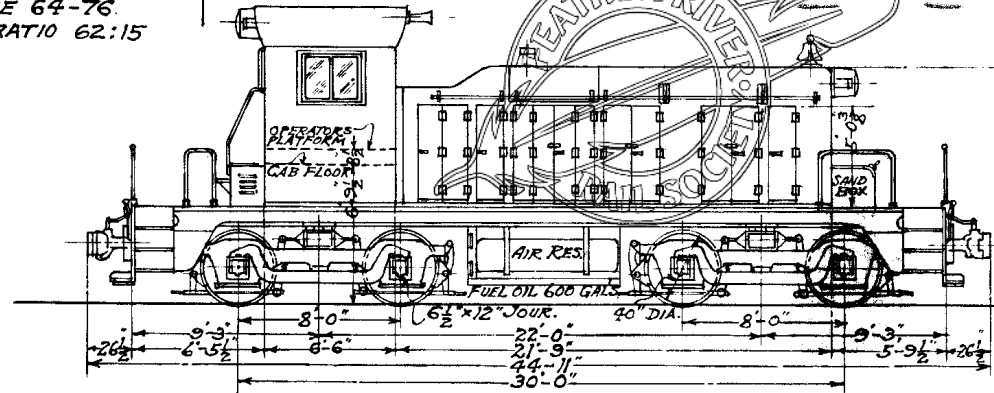

\* NOTE  
 INCLUDES FULL LOAD  
 FUEL, SAND, LUB. OIL, WATER, ALL EQUIPT.  
 AND 2 MEN IN CAB.

Nos. S.N. 403-404  
 DATE BUILT - No.403, 1945  
                   - No.404, 1949

MODEL - ALCO S-2  
 POWER PLANT  
 1-1000 H.P. DIESEL ELECTRIC UNIT  
 DIESEL ENGINE A.L.Co. 539  
 6-12½"x13" CYLS. VERT., 4 CYCLE.  
 GENERATORS  
 1-GE. D.C. TYPE 553C  
 1-GE. EXCITER, TYPE GMC. 139AC

## DIESEL-ELECTRIC SWITCHING 8-WHEEL

TRACTION MOTORS  
 4-GE. D.C. TYPE 731  
 GEAR RATIO 75:16  
 CONTROL EQUIPMENT  
 G.E. TYPE P  
 AIR COMPRESSOR  
 1-WESTINGHOUSE TYPE 3-CD

BRAKE EQUIPMENT  
 WESTINGHOUSE EL-14  
 CLASP BRAKES  
 FUEL - DIESEL OIL ..... 635 GALS.  
 LUBE OIL ..... 80 "  
 ENGINE COOLING WATER 240 "  
 SAND ..... 2700 LBS.

ROAD CLASS 403  
 SYMBOL S-57  
 WEIGHT IN WORKING ORDER  
 (INCL. FULL FUEL OIL, LUBE OIL,  
 WATER, SAND, EQUIPMENT &  
 CREW) - 230,000 LBS.  
 AXLE LOAD - 57,500 LBS.  
 TOTAL LIGHT WEIGHT. 220,100

TRACTION EFFORT - 57,500 LBS.  
 MAX. PERMISSIBLE SPEED 60MPH.  
 MAX. TRACK CURVE 50 FT. RADIUS

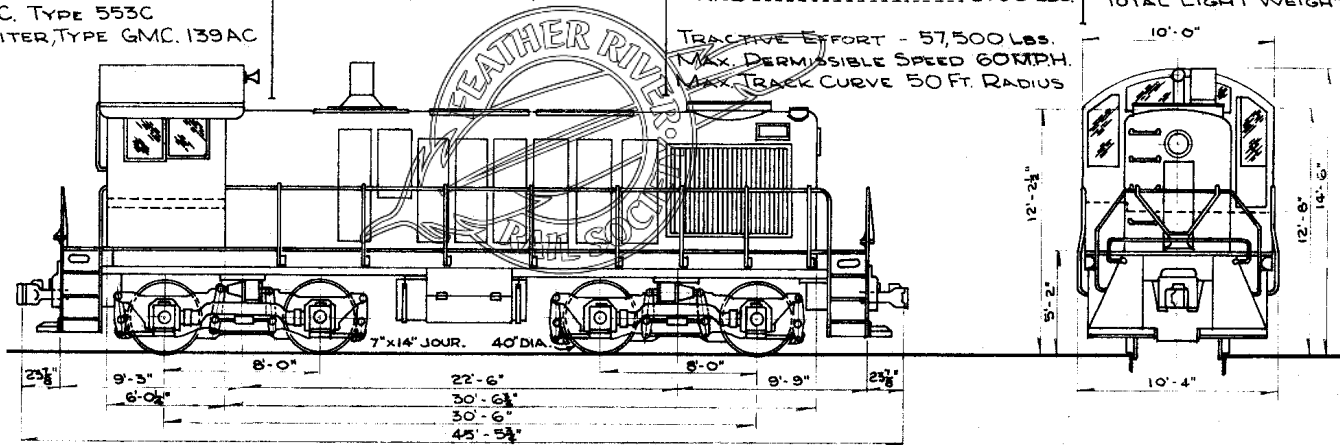

BOX CAR, CLASS XM  
 BUILT BY MT. VERNON CAR MFG. CO.  
 1917-18

CAR NOS SN 2301-2327

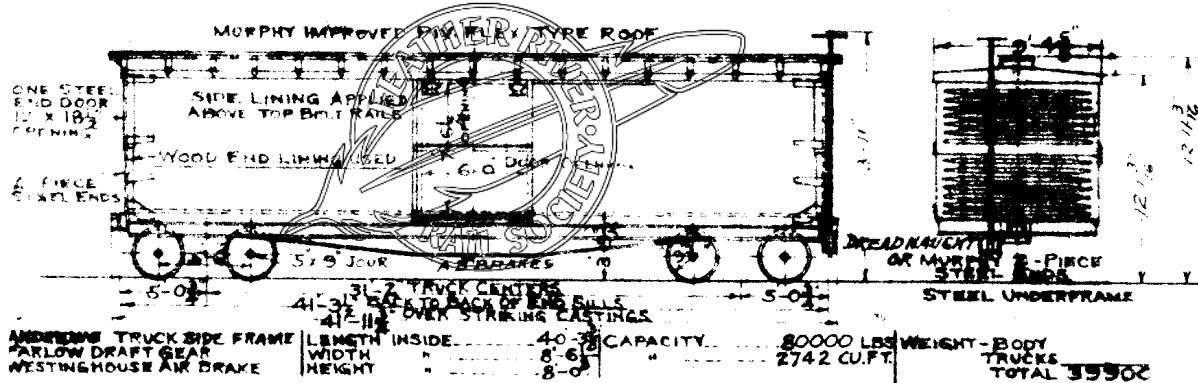

BOX CAR, CLASS XM  
 BUILT BY MT. VERNON CAR MFG. CO.

CAR NOS. S.N. 2329-2350

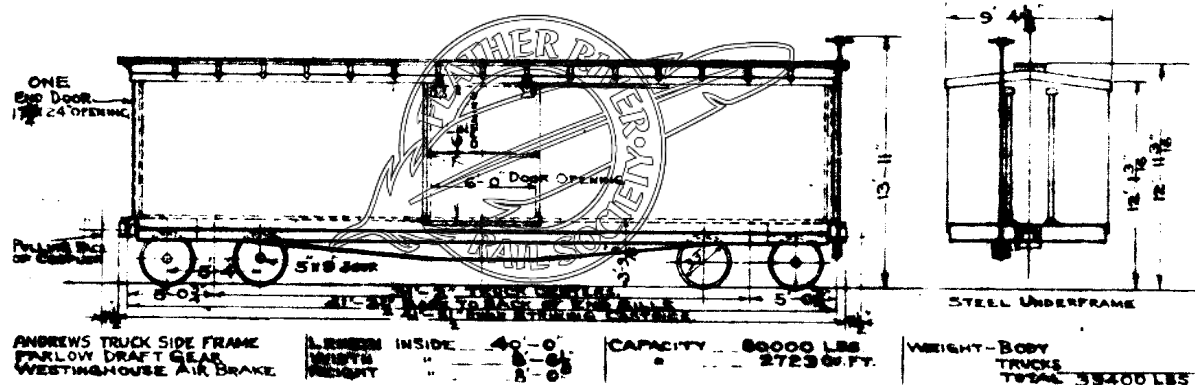

RWC 5-15-58

BUILDERS LOT NO. 8268-B

BOX CAR, CLASS XM  
 BUILT BY PULLMAN STANDARD CAR MFG. CO.  
 AFE S.N. 27-55

CAR NOS. S.N. 2401-2500  
 ORIG. NO. OF CARS 100

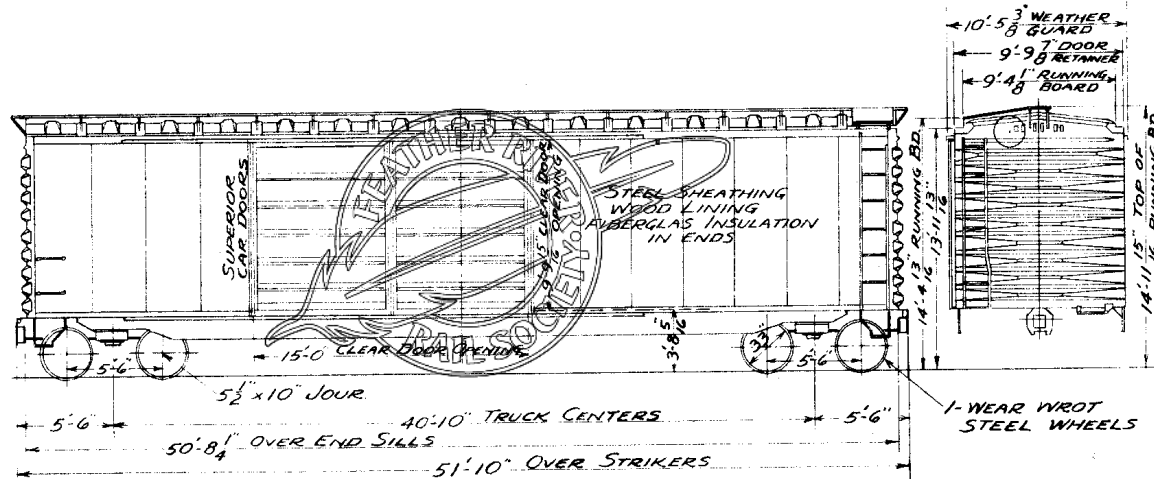

BARBER S-2-C STABILIZED TRUCKS	LENGTH INSIDE	50'-5 <sup>9</sup> / <sub>16</sub> "	CAPACITY	100000 LBS.	WEIGHT - BODY
RUBBER DRAFT GEARS	WIDTH	9'-2 <sup>1</sup> / <sub>16</sub> "	"	4840 CU. FT.	TRUCKS
WESTINGHOUSE TYPE AB1012 AIR BRAKES	HEIGHT	10'-5 <sup>1</sup> / <sub>2</sub> "			TOTAL 55800 LBS.

RWC 4-22-58

BUILDERS LOT NO. 01-5124

DROP BOTTOM GONDOLA, CLASS GS  
 BUILT BY AMERICAN CAR & FOUNDRY CO.  
 AFE SN. 16-57

CAR NOS. S.N. 4001-4020  
 ORIG. NO. OF CARS 20

ALL CARS EQUIPPED WITH  
 LUBRICATOR PADS.

TYPE "A" CAST  
 STEEL WHEELS

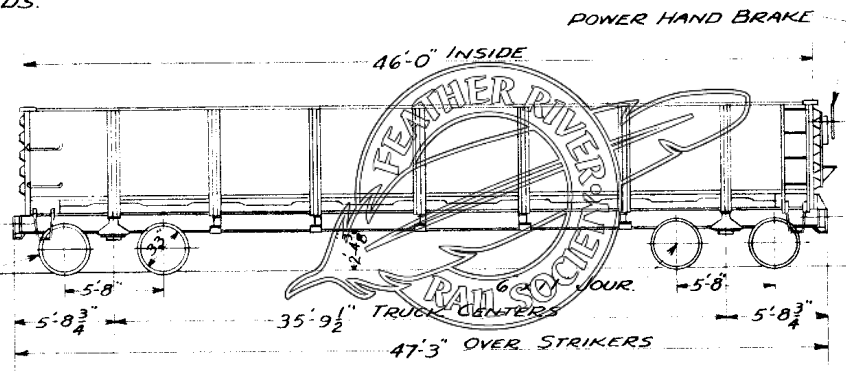

← 10'-8" OVER SIDE STAKES →  
 ← 10'-7 7/8" OVER CORNER CAPS →  
 ← 9'-9 7/8" INSIDE →

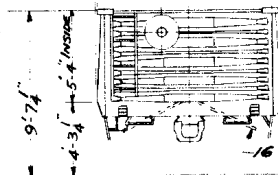

16 DROP DOORS

DOOR OPERATING MECHANISM  
 BY ENTERPRISE RLWY. EQUIP. CO.

ASF A-3 RIDE CONTROL TRUCKS	LENGTH INSIDE	46'-0"	CAPACITY	140000 LBS	WEIGHT - BODY TRUCKS
CARDWELL-WEST NY-11-F DRAFT GEAR	WIDTH	9'-9 7/8"	"	2410 CUFT	
WESTINGHOUSE TYPE AB 1012 AIR BRAKES	HEIGHT	5'-4"	"	LEVEL FULL	TOTAL 56300 LBS



REV:  
5-22-68

BUILDERS LOT 5363

GONDOLA CARS, CLASS GB  
BUILT BY AMERICAN CAR & FDRY, JULY 1959  
AFE S.N. 4-59

CAR NOS. S.N. 4501-4525  
NO. OF CARS 25

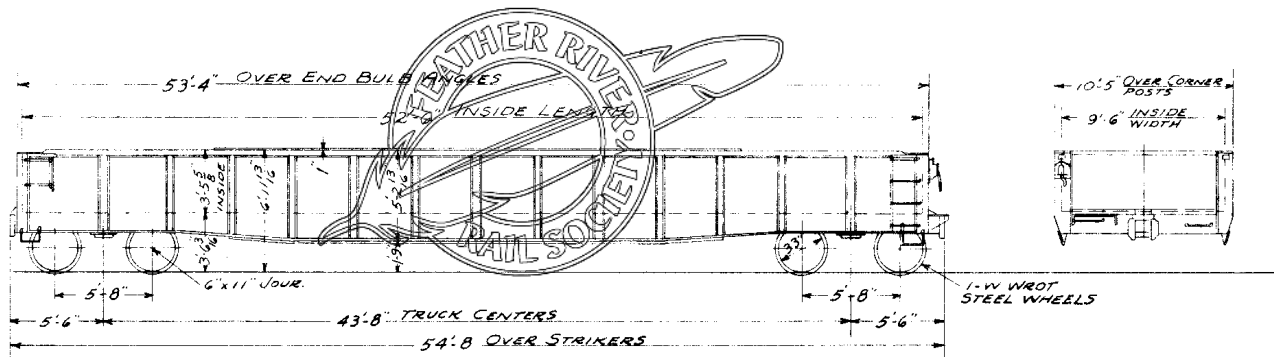

BARBER S-2-A STABILIZED TRUCKS  
MINER A-22-XL DRAFT GEARS  
ROLLER BEARINGS

LENGTH INSIDE	52'-6"
WIDTH	9'-6"
HEIGHT	3'-5 <sup>5</sup> / <sub>8</sub> "

CAPACITY	140,000 LBS.
	1728 CU.FT.

WEIGHT-BODY	39590
TRUCKS	16440
TOTAL	56030 LBS.

RWC 3-8-60

BUILDERS LOT NO. 11-5259

COVERED HOPPER CAR, CLASS LO  
BUILT BY AMERICAN CAR & FOUNDRY CO.

CAR NOS. S.N. 5001-5010  
ORIG. NO. OF CARS 10

ALL CARS EQUIPPED  
WITH LUBRICATOR PADS.

AFE S.N. 2-59

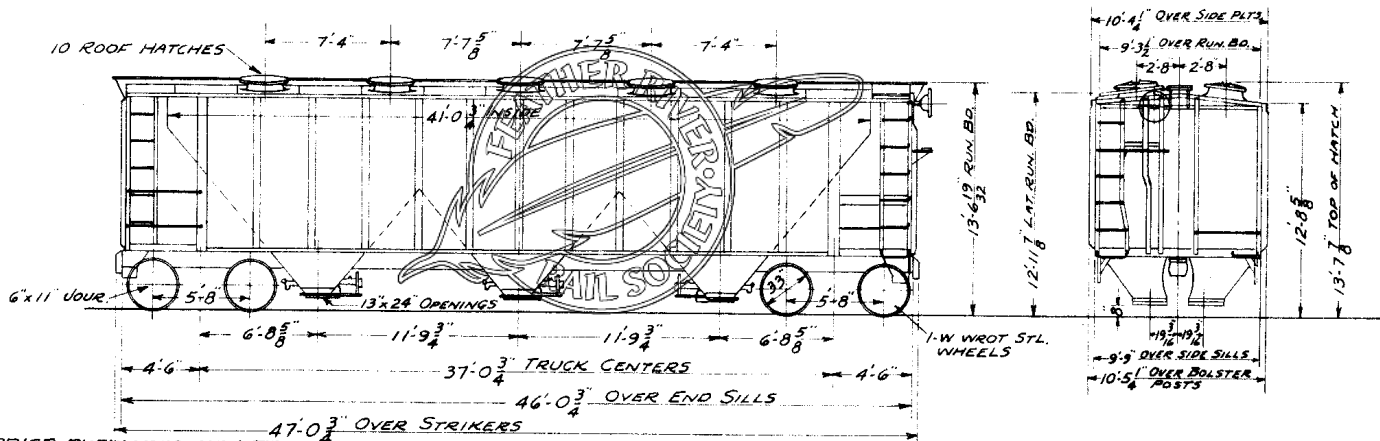

ENTERPRISE PNEUMATIC OUTLETS  
TRUCKS, ASF A-3 RIDE CONTROL  
DRAFT GEAR, AAR APPROVED  
AIR BRAKES, WESTINGHOUSE TYPE AB-1012

LENGTH INSIDE 41'-0<sup>3</sup>/<sub>4</sub>"  
WIDTH " 9'-9"

CAPACITY 140,000 LBS.  
3200 CUFT.

WEIGHT-BODY 47210  
TRUCKS 16440  
TOTAL 63650 LB.

RWC 11-3-58

BUILDERS LOT 8460-G

COVERED HOPPER CARS, CLASS LO  
 BUILT BY PULLMAN STANDARD MAY 1959  
 AFE S.N. 4-59

CAR NOS. S.N. 5011-5020  
 NO. OF CARS 10

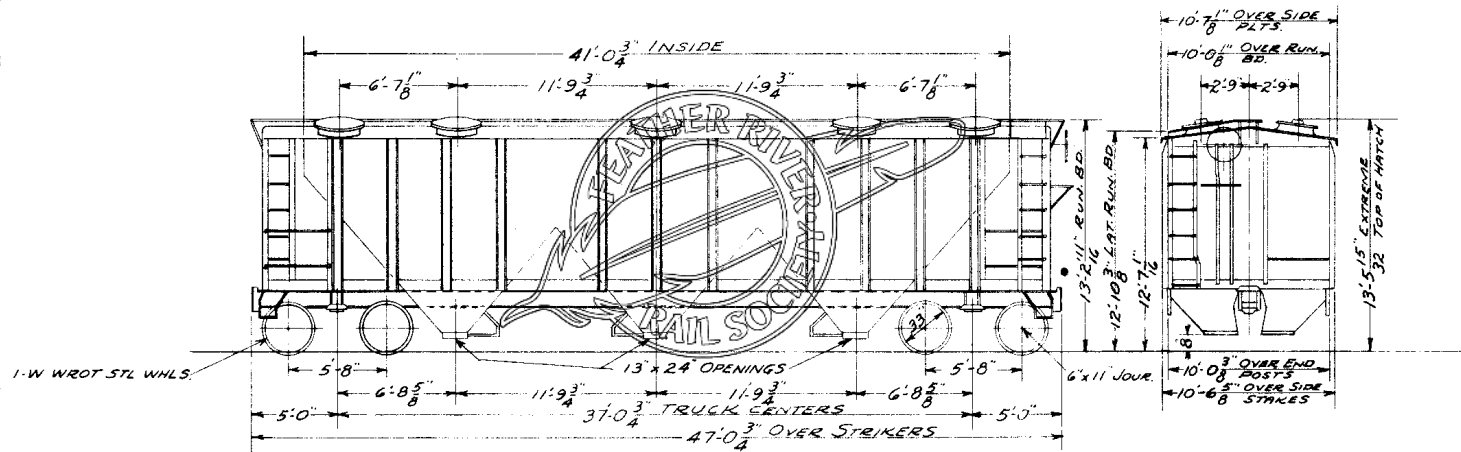

ENTERPRISE PNEUMATIC OUTLETS  
 ASF A-3 RIDE CONTROL TRUCKS  
 WAUGH NO. 420 DRAFT GEARS  
 TIMKEN AP ROLLER BEARINGS

LENGTH INSIDE  
 WIDTH "

41'-0<sup>3</sup>/<sub>4</sub>"  
 9'-11<sup>5</sup>/<sub>8</sub>"

CAPACITY  
 "

140,000 LBS.  
 3219 CU.FT.

WEIGHT-BODY 46260  
 TRUCKS 16440

TOTAL 62700 LBS.

RWC 3-10-60

BUILDERS LOT 11-5389-E

COVERED HOPPER CARS, CLASS L0  
 BUILT BY AMERICAN CAR & FOUNDRY MARCH 1960  
 AFE S.N. 12-60

CAR NOS. S.N. 5101-5110  
 NO. OF CARS 10

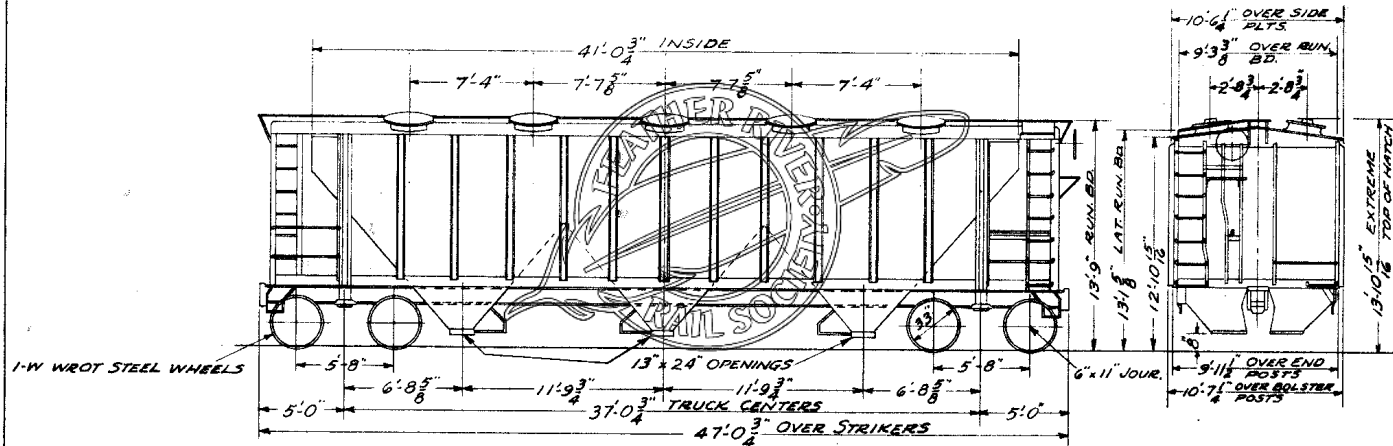

KEYSTONE OUTLET GATES  
 ASF A-3 RIDE CONTROL TRUCKS  
 DRAFT GEAR AAR APPROVED  
 TIMKEN AP ROLLER BEARINGS

RWC 4-6-60

LENGTH INSIDE  
 WIDTH "

41'0 <sup>3</sup>/<sub>4</sub>"  
 9'-11"

CAPACITY  
 "

140,000 LBS.  
 3500 CU. FT.

WEIGHT-BODY 45760  
 TRUCKS 16440  
 TOTAL 62200

BUILDERS LOT 11-5778

ALUMINUM COVERED HOPPER CARS CLASS L0

CAR NOS S.N. 5501-5510

BUILT BY AMERICAN CAR & FOUNDRY NOV. 1961

NO. OF CARS 10

AFE S.N. 28-61

NOTE:

END COMPARTMENTS 1152 CU.FT. EACH  
 CENTER COMPARTMENTS 823 CU.FT. EACH

REV. 2-24-64

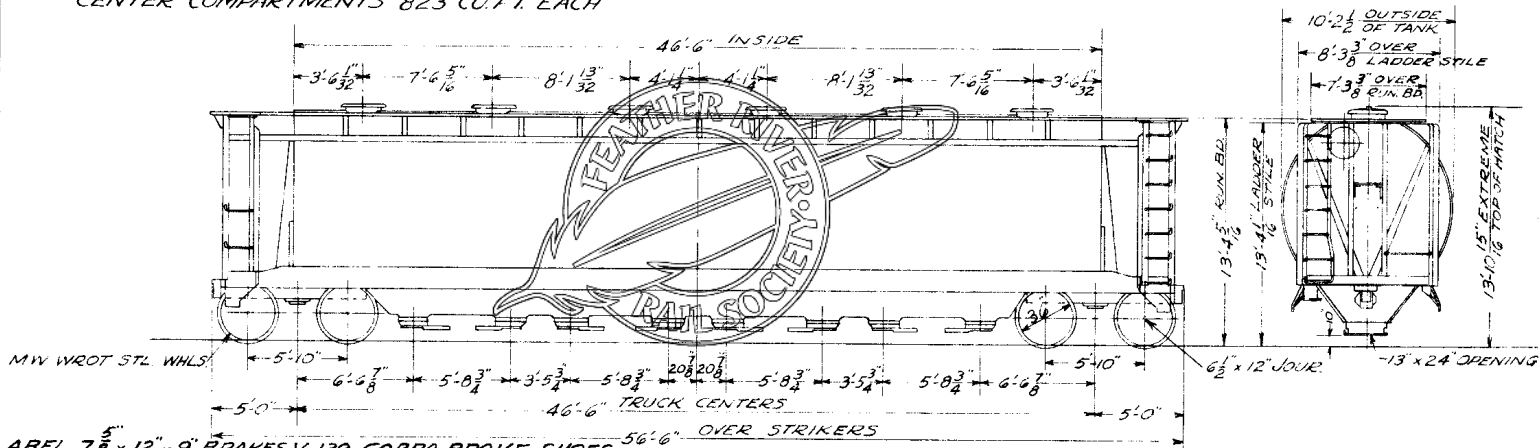

ABEL 7 5/8" x 12" x 9" BRAKES V-139 COBRA BRAKE SHOES

KEYSTONE OUTLET GATES

ASF A-3 RIDE CONTROL TRUCKS

NATIONAL MF-400A RUBBER DRAFT GEAR

TIMKEN AP ROLLER BEARINGS

LENGTH INSIDE

46'-6"

CAPACITY

200,000 LBS.

WEIGHT-BODY 22700

WIDTH

"

"

3950 CU.FT.

" -TRUCKS 21600

TOTAL 44300

RWC 11-14-61

INSULATED BOX CARS, CLASS RBL  
 BUILT BY THRALL CAR MFG. CO. DEC. 1961

CAR NOS S.N. 8001-8040  
 NO. OF CARS 40

REV. 4-22-63

S.N.	CAR PAC LOADERS	LENGTH OF TRAVEL & TYPE OF CUSHION UNDERFRAME	ROLLER BEARINGS	WEIGHT	DISTANCE OVER STRIKERS	DRAFT GEARS
8001-8005	4 BELT	24"-NATIONAL	SKF	74800	56'-5 <sup>3</sup> / <sub>16</sub> "	NAT'L CSTG'S MS-130
8006-8010	6 BELT	24"-NATIONAL	SKF	75400	"	NAT'L CSTG'S MS-430
8011-8032	6 BELT	20"-KEYSTONE	TIMKEN	75600	55'-7 <sup>1</sup> / <sub>16</sub> "	MINER A-22-XL
8033-8040	6 BELT	20"-KEYSTONE	HYATT	75600	"	MINER A-22-XL

AFE S.N. 28-61

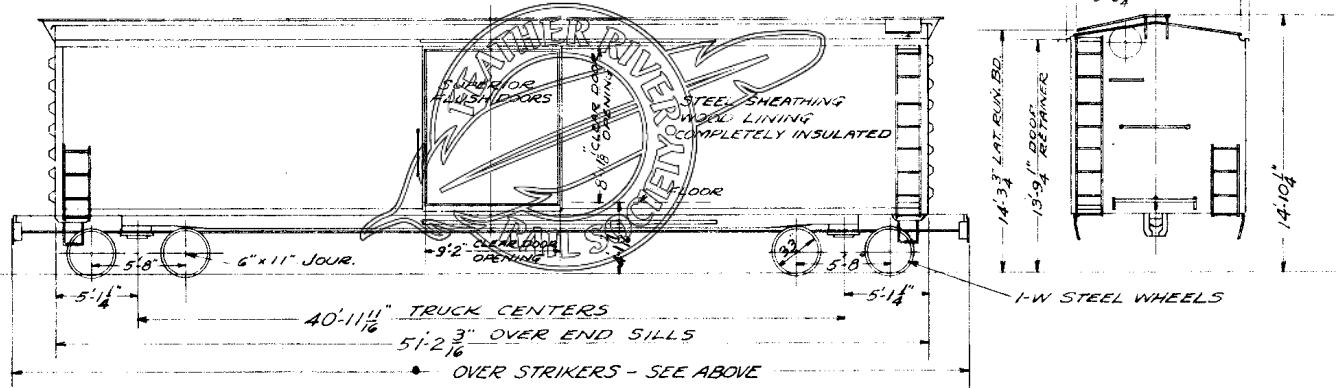

ASF A-3 RIDE CONTROL TRUCKS  
 DRAFT GEARS - SEE ABOVE  
 ROLLER BEARINGS - SEE ABOVE

LENGTH INSIDE 50'-6"  
 WIDTH " 9'-4"  
 HEIGHT " 9'-6"

CAPACITY "

133000 LBS  
 4477 CUFT

WEIGHT-BODY TRUCKS 16440  
 TOTAL SEE ABOVE

RWC 11-16-61