

LOCOMOTIVE & FREIGHT EQUIPMENT
SACRAMENTO NORTHERN RAILWAY
AND
TIDEWATER SOUTHERN RAILWAY

J.F. PEARCE (1964)

LOCOMOTIVE & FREIGHT EQUIPMENT
SACRAMENTO NORTHERN RAILWAY

Diesel Electric Switching 8-Wheel Road Class SN-142
Diesel Electric Switching 8-Wheel Road Class SN-201
Diesel Electric Switching 8-Wheel Road Class SN-301
Box Car Class XM Car Numbers SN 2301-2327
Box Car Class XM Car Numbers SN 2329-2350
Box Car Class XM Car Numbers SN 2401-2500
Drop Bottom Gondola Class G5 Car Numbers SN 4001-4020
Gondola Cars Class GB Car Numbers SN 4501-4525
Covered Hopper Car Class L0 Car Numbers SN 5001-5010
Covered Hopper Car Class L0 Car Numbers SN 5011-5020
Covered Hopper Car Class L0 Car Numbers SN 5101-5110
Aluminum Covered Hopper Cars Class L0 Car Numbers SN 5501-5510
Insulted Box Cars Class RBL Car Numbers SN 8001-8040

LOCOMOTIVE & FREIGHT EQUIPMENT
TIDEWATER SOUTHERN RAILWAY

Diesel Electric Switching 8-Wheel Road Class TS 735
Diesel Electric Switching 8-Wheel Road Class TS 741
Drop Bottom Gondola Class G5 Car Numbers TS 201-205
Box Car Class XM Car Numbers TS 501-525
Insulted Box Cars Class RBL Car Numbers TS 601-610
Insulted Box Cars Class RBL Car Numbers TS 611-620

-Transcribed Paul Finnegan 5/14/2021

J.F. PEARCE

LOCOMOTIVE & FREIGHT
EQUIPMENT

SACRAMENTO NORTHERN RAILWAY
AND

TIDEWATER SOUTHERN RAILWAY

*LOCOMOTIVE & FREIGHT
EQUIPMENT*

SACRAMENTO NORTHERN RAILWAY



S
7

SNRY. Nos. 142-147 No. of LOCO'S 6
 BUILT-GEN. ELEC. CO.
 LOCO'S 142-146, 1946
 LOCO. 147, 1942
 POWER PLANT
 2-190 H.P. CATERPILLAR DIESEL
 ENGINES TYPE D-17000
 8-5 $\frac{3}{4}$ " x 8" CYLS. "V" TYPE, 4 CYCLE
 GENERATORS
 2-G.E. DIRECT CURRENT TYPE GT-555
 2-G.E. EXCITER TYPE G.M.G.-140
 TRACTION MOTORS
 4 G.E. DIRECT CURRENT TYPE G.E.-733
 GEAR RATIO 11.25 TO 1

DIESEL-ELECTRIC SWITCHING 8-WHEEL ROAD CLASS SN-142

AIR COMPRESSOR
 2 GARDNER-DENVER TYPE ADS
 BRAKE EQUIPMENT
 WESTINGHOUSE A.B. Co. STRAIGHT
 AND AUTOMATIC SCHEDULE 14-EL

FUEL - DIESEL OIL ----- 250 GALS
 LUBR. ----- 100 GALS
 ENGINE COOLING WATER 80 GALS
 SAND 800 LBS

TRACTIVE POWER 26,400 LBS
 MAX. PERMISSIBLE SPEED 35 MPH
 MAX. TRACK CURVE 50 FT RADIUS

SYMBOL S-26
 FUEL DIESEL OIL
 * WEIGHTS IN WORKING ORDER
 TOTAL ON DRIVERS 88,000 LBS
 TOTAL DRY (LIGHT) WT. 84,900 LBS
 AXLE LOAD 22,000 LBS.

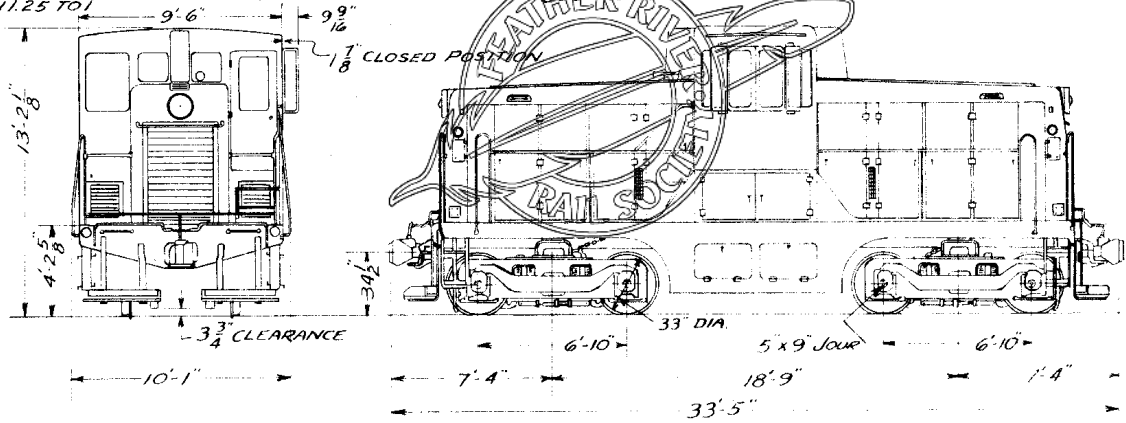

NOTE:
 * INCLUDES FULL LOAD
 FUEL OIL, LUBR OIL, WATER,
 SAND, ALL EQUIP. & 2 MEN.

S.N.RY. Nos. 201-202 No. of LOCO'S. 2 **DIESEL-ELECTRIC SWITCHING 8-WHEEL**

BUILT-GEN. ELEC. CO.

LOCO. 201 1955 SPEC. No. RY-24224-D

LOCO. 202 1956 SPEC. No. RY-24224-E

POWER PLANT

LOCO. 201, 600 HP

LOCO. 202, 720 HP

COOPER-BESSEMER

DIESEL ENGINE TYPE FWL-6T

6-9" x 10 1/2" CYLS., IN LINE TYPE, 4 CYCLE

GENERATORS

1-G.E. DIRECT CURRENT TYPE GT-571

1-G.E. EXCITER TYPE G.M.G.-146

TRACTION MOTORS

4 G.E. DIRECT CURRENT TYPE G.E. 748

GEAR RATIO 105:15

AIR COMPRESSOR

1 WESTINGHOUSE MODEL 2CB

BRAKE EQUIPMENT

NEW YORK A. B. CO. STRAIGHT

& AUTOMATIC SCHEDULE 14-EL

FUEL-DIESEL OIL 500 GALS.

LUBR. 125 GALS.

ENG. COOLING WATER 100 GALS.

SAND 1250 LBS.

TRACTION POWER 41,300 LBS.

MAX. PERMISSIBLE SPEED 55 MPH

MAX TRACK CURVE 75 FT RADIUS

ROAD CLASS SN-201

SYMBOL S-41

FUEL-DIESEL OIL

* WEIGHTS IN WORKING ORDER

TOTAL ON DRIVERS 139,000 LBS.

TOTAL DRY (LIGHT) WGT. 132,800 LBS.

AXLE LOAD 34,400 LBS.

NOTE:

* INCLUDES FULL LOAD FUEL OIL, LUBR. OIL, WATER, SAND, ALL EQUIP. AND 2-MEN.

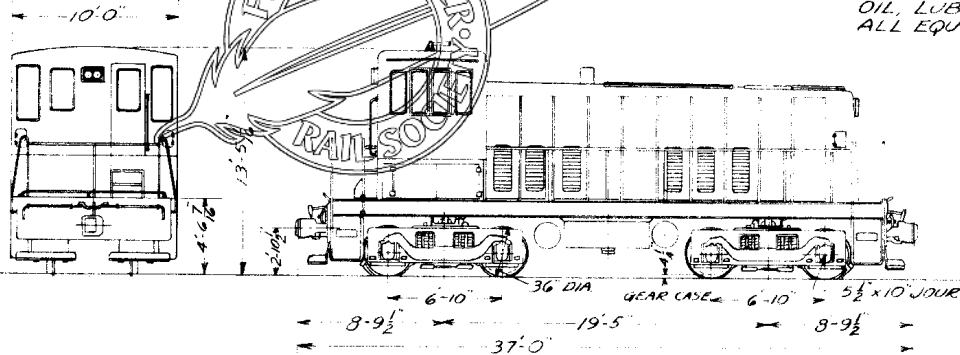

S.N.R.Y. Nos 301-A, 301-D No. of LOCO'S 2

W.P.R.R. No. 801-D No. of LOCO'S 1

BUILT-ELECTRO-MOTIVE DIVN.-G.M.C. 1948

POWER PLANT

1-1500 H.P. GMC DIESEL ELECTRIC UNIT
DIESEL ENGINE 16-8 1/2" x 10" CYLS. V TYPE,
2 CYCLE, MODEL 16-567-B

MAIN GENERATOR

1-EMD. TYPE D-12-14 NOM VOLTAGE 600

TRACTION MOTORS

LOCO'S S.N. 301-302
4 EMD. TYPE D-7-E VOLTAGE 600
LOCO. W.P. 801-D
4 EMD. TYPE D-27-B VOLTAGE 600

GEAR RATIO

LOCO'S S.N. 301-302 65:12
LOCO. W.P. 801-D 62:15

DIESEL-ELECTRIC FREIGHT 8-WHEEL

AIR COMPRESSOR

1 GARDNER-DENVER TYPE WXE

BRAKE EQUIPMENT

WESTINGHOUSE CLASP BRAKES
TYPE 24 RL

FUEL DIESEL OIL **1200 GALS.

LUBE OIL 200 "

ENG. COOLING WATER 230 "

TOILET 50 "

SAND 1600 LBS.

** EXCEPT 801-D, 1500 GALS.

TRACTIVE POWER 59,000 LBS

MAX. TRACK CURVE 21°

MAX. PERMISSIBLE SPEED

LOCO'S S.N. 301-302 50 M.P.H.
LOCO. W.P. 801-D 65 M.P.H.

MIN. CONTINUOUS RATING SPEED

1 M.P.H.

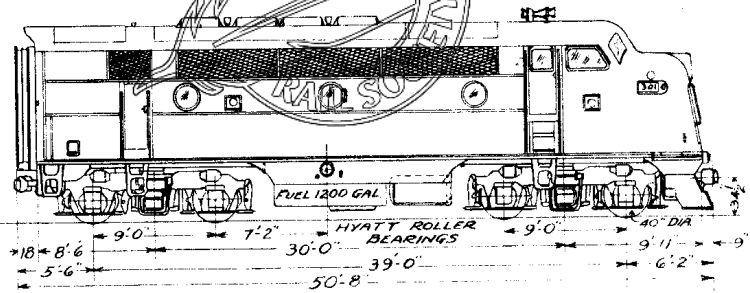

ROAD CLASS S.N. 301
SYMBOL

FUEL - DIESEL OIL

*WEIGHTS IN WORKING ORDER
TOTAL ON DRIVERS 236,500 LBS.
TOTAL DRY (LIGHT) WT 213,970 LBS.
AXLE LOAD 59,125 LBS.

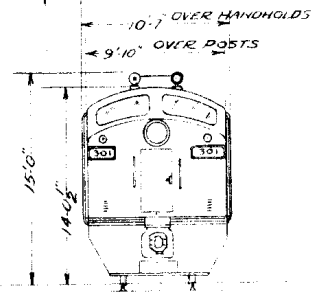

NOTE:
* INCLUDES FULL LOAD OF FUEL OIL,
LUBE OIL, WATER, SAND, ALL EQUIPT.

BOX CAR, CLASS XM
 BUILT BY MT. VERNON CAR MFG. CO.
 1917-18

CAR NOS. S.N. 2301-2327

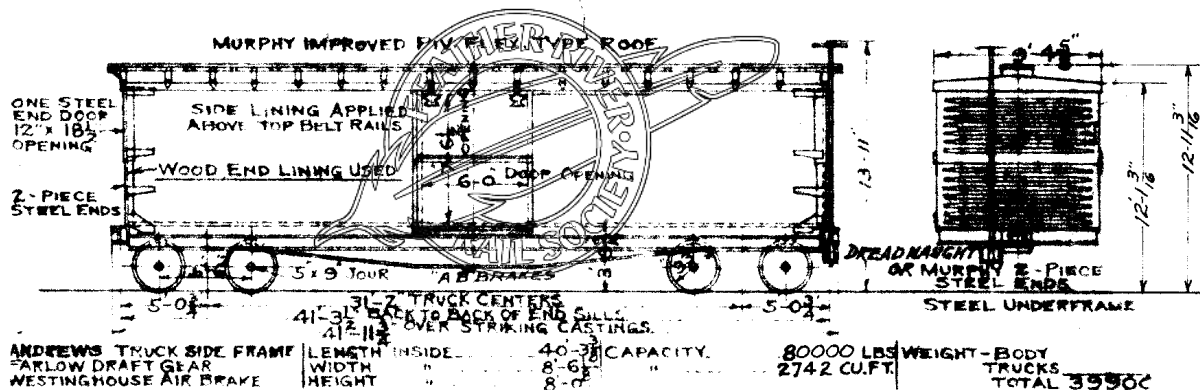

BOX CAR, CLASS XM
 BUILT BY MT. VERNON CAR MFG. CO.

CAR NOS. S.N. 2329-2350

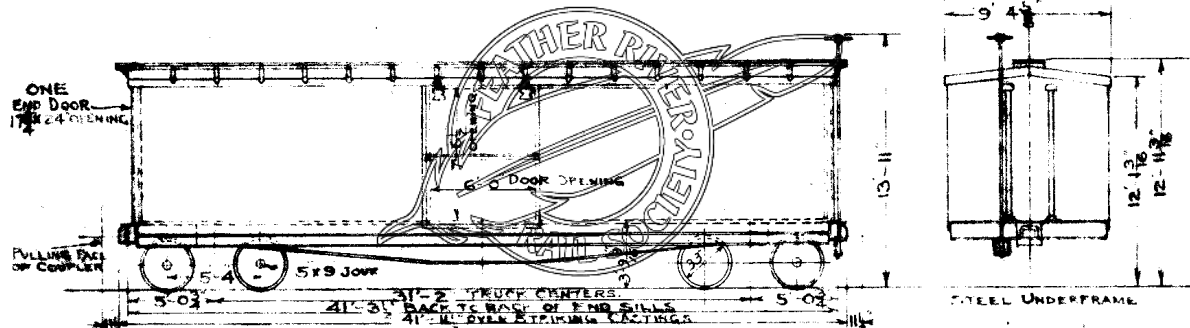

ANDREWS TRUCK SIDE FRAME
 FARLOW LEAF GEAR
 WESTINGHOUSE AIR BRAKE

LENGTH INSIDE	40'-0"
WIDTH	8'-6 1/2"
HEIGHT	8'-0"

CAPACITY	80000 LBS
	2723 CU. FT

WEIGHT-BODY	
TRUCKS	
TOTAL	35400 LBS

BUILDERS LOT NO. 8268-B

BOX CAR, CLASS XM
BUILT BY PULLMAN STANDARD CAR MFG. CO.
AFE S.N. 27-55

CAR NOS. S.N. 2401-2500
ORIG. NO. OF CARS 100

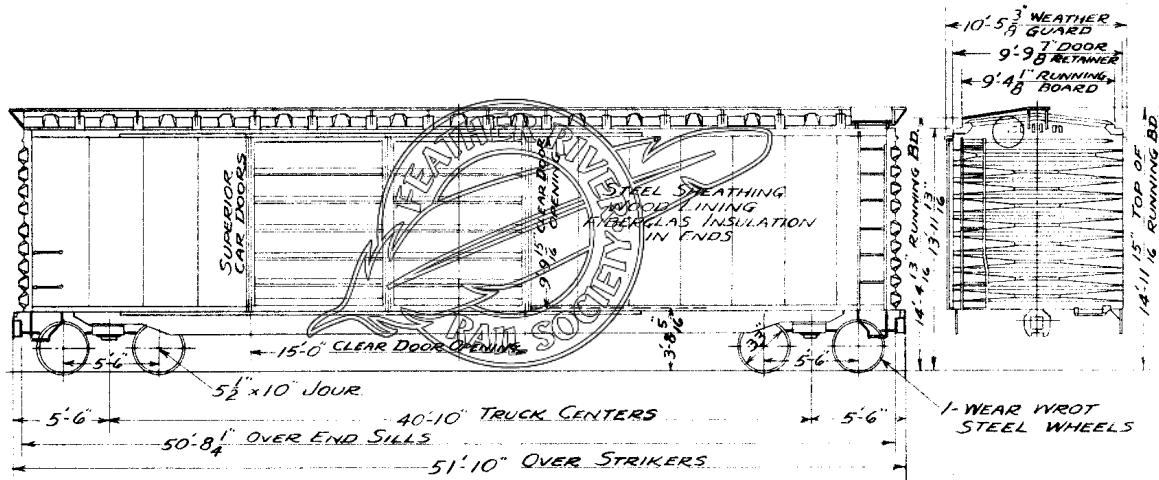

BARBER S-2-C STABILIZED TRUCKS
RUBBER DRAFT GEARS
WESTINGHOUSE TYPE AB1012 AIR BRAKES

LENGTH INSIDE	50'-5 3/8"
WIDTH	9'-2 1/8"
HEIGHT	10'-5 1/2"

CAPACITY	100000 LBS.
	4840 CU. FT.

WEIGHT - BODY TRUCKS	
TOTAL	55800 LBS.

BUILDERS LOT NO. 01-5124

DROP BOTTOM GONDOLA, CLASS GS
 BUILT BY AMERICAN CAR & FOUNDRY CO.
 AFE SN. 16-57

CAR NOS. S.N. 4001-4020
 ORIG. NO. OF CARS 20

ALL CARS EQUIPPED WITH
 LUBRICATOR PADS.

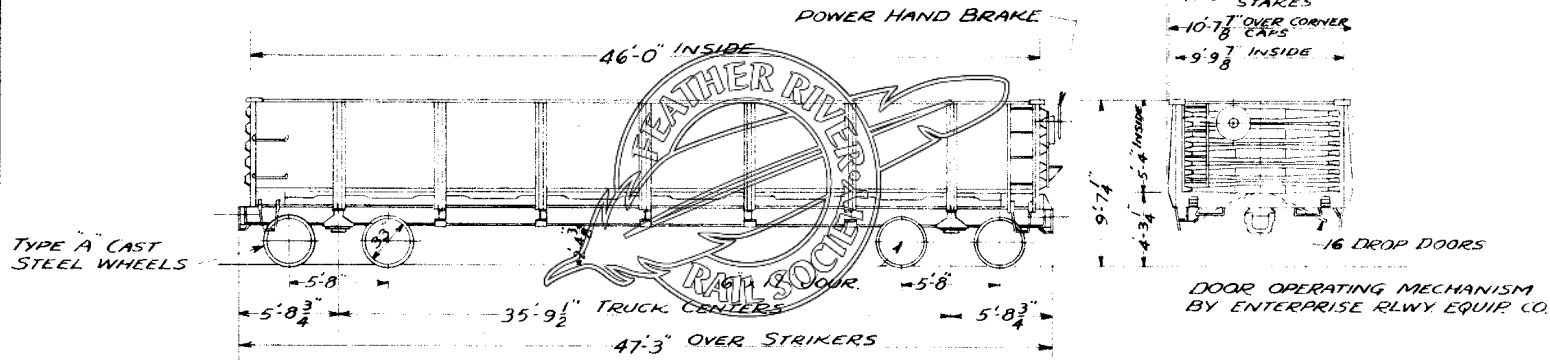

ASF A-3 RIDE CONTROL TRUCKS
 CARDWELL-WEST, NY-11-F DRAFT GEAR
 WESTINGHOUSE TYPE AB 1012 AIR BRAKES

LENGTH INSIDE 46'-0"
 WIDTH " 9'-9 7/8"
 HEIGHT " 5'-4"

CAPACITY 140000 LBS
 " 2410 CU FT
 LEVEL FULL

WEIGHT - BODY TRUCKS
 TOTAL 56300 LBS

BUILDERS LOT 5363

GONDOLA CARS, CLASS GB

BUILT BY AMERICAN CAR & FDRY. JULY 1959

AFE S.N. 4-59

CAR NOS. S.N. 4501-4525

NO. OF CARS 25

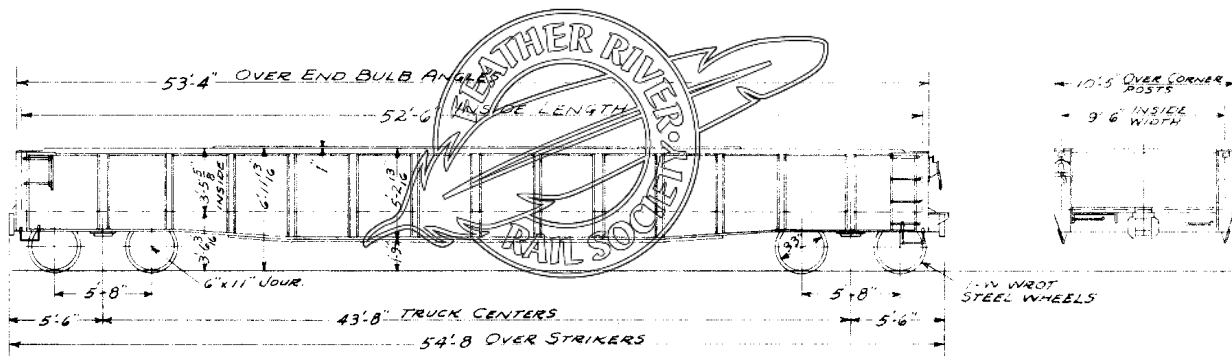

BARBER S-2-A STABILIZED TRUCKS
 MINER A-22-XL DRAFT GEARS
 KAR-GO BEARINGS

LENGTH INSIDE	52'-6"
WIDTH	9'-6"
HEIGHT	3'-5 1/2"

CAPACITY	140,000 LBS.
	1728 CU.FT.

WEIGHT - BODY	39590
TRUCKS	16440
TOTAL	56030 LBS.

BUILDERS LOT NO 11-5259

COVERED HOPPER CAR, CLASS LO
BUILT BY AMERICAN CAR & FOUNDRY CO.

CAR NOS. S.N. 5001-5010
ORIG. NO. OF CARS 10

ALL CARS EQUIPPED
WITH LUBRICATOR PADS.

AFE S.N. 2-59

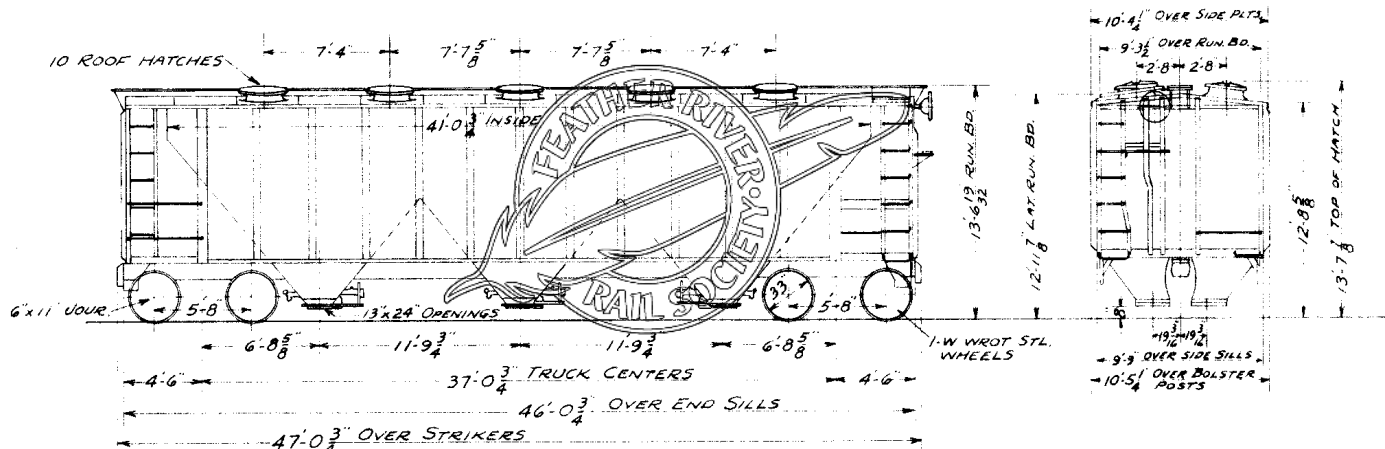

ENTERPRISE PNEUMATIC OUTLETS
TRUCKS, ASF A-3 RIDE CONTROL
DRAFT GEAR, AAR APPROVED
AIR BRAKES, WESTINGHOUSE TYPE AB-1012

LENGTH INSIDE 41'-0³/₄"
WIDTH " 9'-9"

CAPACITY 140,000 LBS.
" 3200 CU.FT.

WEIGHT-BODY 47210
TRUCKS 16440
TOTAL 63650 LB.

BUILDERS LOT 8460-G

COVERED HOPPER CARS, CLASS LO
 BUILT BY PULLMAN STANDARD MAY 1959
 AFE S.N. 4-59

CAR NOS S.N. 5011-5020
 NO. OF CARS 10

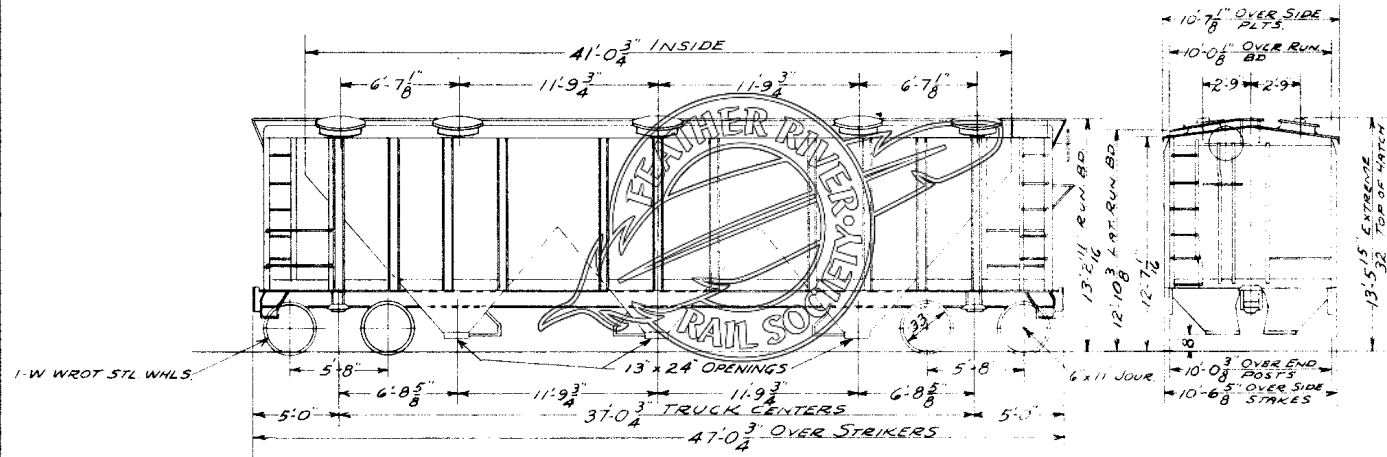

ENTERPRISE PNEUMATIC OUTLETS
 ASF A-3 RIDE CONTROL TRUCKS
 WAUGH NO. 420 DRAFT GEARS
 TIMKEN AP ROLLER BEARINGS

LENGTH INSIDE
 WIDTH "

41'-0 3/4"
 9'-11 1/8"

CAPACITY
 "

140,000 LBS.
 3219 CU.FT.

WEIGHT-BODY 46260
 TRUCKS 16440
 TOTAL 62700 LBS

BUILDERS LOT 11-5389-E

COVERED HOPPER CARS, CLASS LO
 BUILT BY AMERICAN CAR & FOUNDRY MARCH 1960
 AFE S.N. 12-60

CAR NOS. S.N. 5101-5110
 NO. OF CARS 10

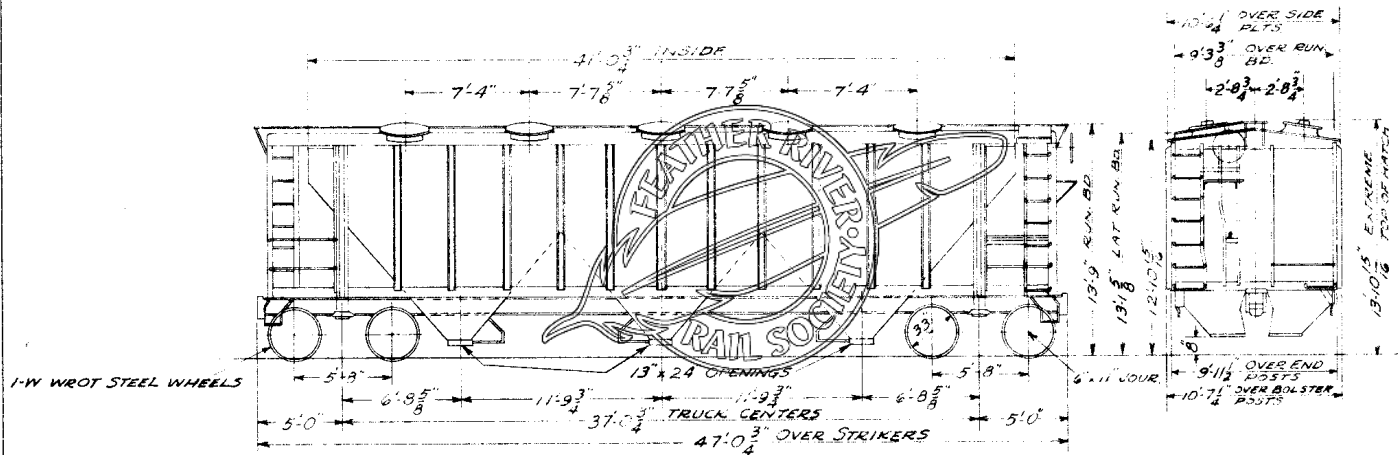

1-W WROT STEEL WHEELS

KEYSTONE OUTLET GATES
 ASF A-3 RIDE CONTROL TRUCKS
 DRAFT GEAR AAR APPROVED
 TIMKEN AP ROLLER BEARINGS

LENGTH INSIDE
 WIDTH "

41'-0 3/4"
 9'-11"

CAPACITY

140,000 LBS.
 3500 CUFT

WEIGHT: BODY 45160
 TRUCKS 16440
 TOTAL 61600

BUILDERS LOT 11-5778

ALUMINUM COVERED HOPPER CARS CLASS LO

BUILT BY AMERICAN CAR & FOUNDRY NOV. 1961

AFE S.N. 28-61

CAE N^{OS} S.N. 5501-5510

NO. OF CARS 10

NOTE:

END COMPARTMENTS 1152 CU.FT. EACH
 CENTER COMPARTMENTS 823 CU.FT. EACH

4-64

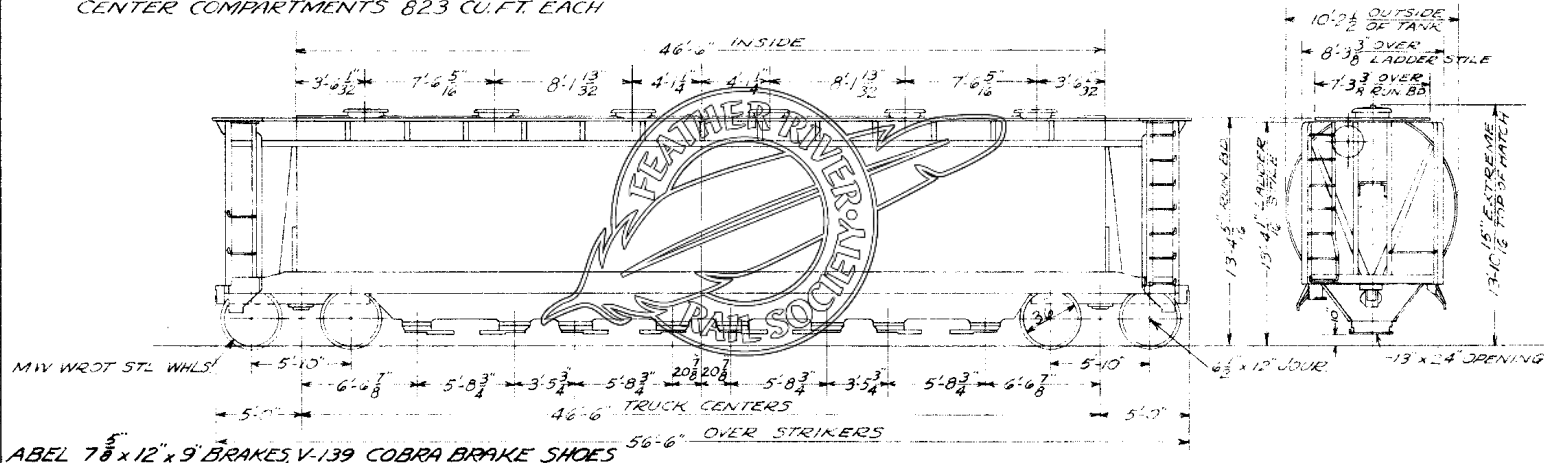

ABEL 7⁵/₈ x 12" x 9" BRAKES, V-139 COBRA BRAKE SHOES

KEYSTONE OUTLET GATES

ASF A-3 RIDE CONTROL TRUCKS

NATIONAL MF-400A RUBBER DRAFT GEAR

TIMKEN AP ROLLER BEARINGS

LENGTH INSIDE

46'-6"

CAPACITY

200,000 LBS.

WEIGHT-BODY

22,700

WIDTH

10'-2"

3950 CU.FT.

-TRUCKS 21,600

TOTAL 44,300

INSULATED BOX CARS, CLASS RBL
 BUILT BY THRALL CAR MFG. CO. DEC. 1961

CAR NOS S.N. 8001-8040
 NO. OF CARS 40

S.N.	CAR PAC LOADERS	LENGTH OF TRAVEL & TYPE OF CUSHION UNDERFRAME	ROLLER BEARINGS	WEIGHT	DISTANCE OVER STRIKERS	DRAFT GEARS
8001-8005	4 BELT	24"-NATIONAL	SKF	74800	56'-5 ³ / ₁₆ "	NATL CSTG'S MS-430
8006-8010	6 BELT	24"-NATIONAL	SKF	75400	"	NATL CSTG'S MS-430
8011-8032	6 BELT	20"-KEYSTONE	TIMKEN	75600	55'-7 ¹ / ₁₆ "	MINER A-22-XL
8033-8040	6 BELT	20"-KEYSTONE	HYATT	75600	"	MINER A-22-XL

AFE S.N. 28-61

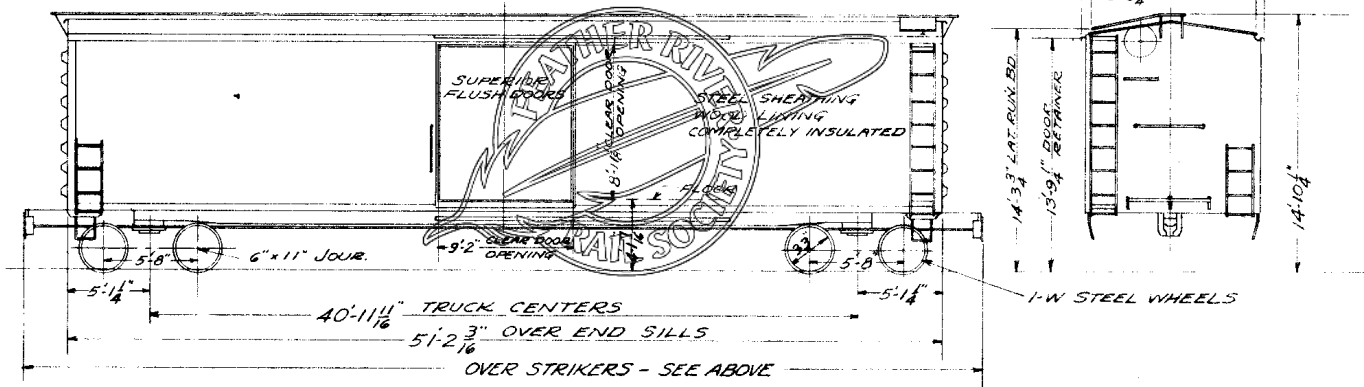

ASF A-3 RIDE CONTROL TRUCKS
 DRAFT GEARS - SEE ABOVE
 ROLLER BEARINGS - SEE ABOVE

LENGTH INSIDE	50'-6"
WIDTH "	9'-4"
HEIGHT "	9'-6"

CAPACITY	133000 LBS
	4477 CU.FT.

WEIGHT - BODY	TRUCKS 16440
TOTAL	SEE ABOVE

*LOCOMOTIVE & FREIGHT
EQUIPMENT*

TIDEWATER SOUTHERN RAILWAY



T.S.R.Y. No. 735 No. of Locos. 1
 BUILT - GEN. ELEC. Co. 1946
 SPEC. NO. RY-24147-G
 POWER PLANT
 2-190 H.P. CATERPILLAR DIESEL
 ENGINES TYPE D-17000
 8-5 $\frac{3}{8}$ x 8" CYLS. V TYPE, 4 CYCLE
 GENERATORS
 2-G.E. DIRECT CURRENT TYPE GT-555
 2-G.E. EXCITER TYPE G.M.G.-140
 TRACTION MOTORS
 4 G.E. DIRECT CURRENT TYPE G.E.-733
 GEAR RATIO 11.25 TO 1
 CONTROL EQUIP.
 G.E. TYPE M.

DIESEL-ELECTRIC SWITCHING 8-WHEEL

ROAD CLASS TS735
 SYMBOL S-26
 FUEL-DIESEL OIL

AIR COMPRESSOR
 2 GARDNER-DENVER TYPE ADS.
 BRAKE EQUIPMENT
 WESTINGHOUSE A.B. Co. STRAIGHT
 AND AUTOMATIC SCHEDULE 14-EL

TRACTIVE POWER 26400 LBS.
 MAX. PERMISSIBLE SPEED 35 M.P.H.
 MAX. TRACK CURVE 50 FT. RADIUS.

*WEIGHTS IN WORKING ORDER
 TOTAL ON DRIVERS 88000 LBS.
 TOTAL DRY (LIGHT) WT. 84,900 LBS.
 AXLE LOAD 22000 LBS.

FUEL-DIESEL OIL ----- 250 GALS.
 LUBR. ----- 100 GALS.
 ENGINE COOLING WATER .. 80 GALS.
 SAND ----- 800 LBS.

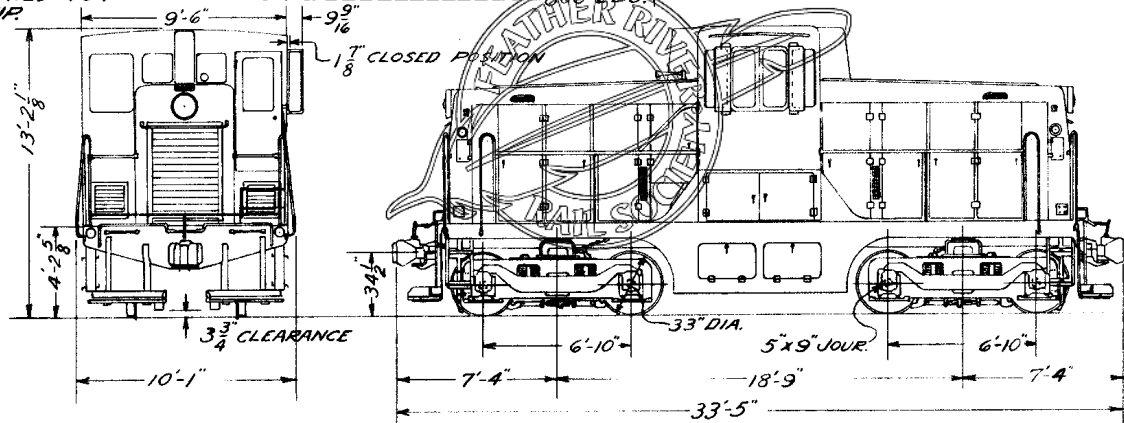

NOTE -
 * INCLUDES FULL LOAD
 FUEL OIL, LUBR. OIL, WATER,
 SAND, ALL EQUIP. & 2 MEN.

T.S. RY. Nos 741-743 No OF LOCO'S 3
BUILT-GEN. ELEC. CO. 1948 (143-1953)

SPEC. No. RY-24224

POWER PLANT

1-600 H.P. COOPER-BESSEMER
DIESEL ENGINE TYPE FWL-6T
6-9" X 10½" CYLS., IN LINE TYPE, 4 CYCLE

GENERATORS

1-G.E. DIRECT CURRENT TYPE GT-571
1-G.E. EXCITER TYPE G.M.G.-146

TRACTION MOTORS

4 G.E. DIRECT CURRENT TYPE G.E. 748

GEAR RATIO 105:15

CONTROL EQUIPMENT
G.E. TYPE M

DIESEL-ELECTRIC SWITCHING 8-WHEEL

AIR COMPRESSOR

1 WESTINGHOUSE MODEL 4ZB

BRAKE EQUIPMENT

NEW YORK A. B. CO. STRAIGHT
& AUTOMATIC SCHEDULE 14-EL

FUEL-DIESEL OIL...500 GALS.

LUBR.125 GALS.

ENG. COOLING WATER...100 GALS.

SAND250 LBS.

TRACTION POWER 41,300 LBS.

MAX. PERMISSIBLE SPEED 55 M.P.H.

MAX. TRACK CURVE 75 FT. RADIUS

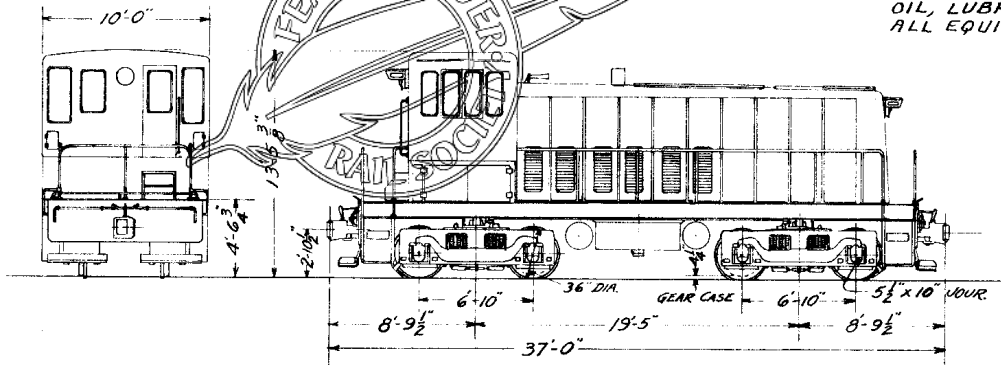

ROAD CLASS TS-741
SYMBOL S-41

FUEL-DIESEL OIL

* WEIGHTS IN WORKING ORDER
TOTAL ON DRIVERS 137,600 LBS.
TOTAL DRY (LIGHT) WT. 132,800 LBS.
AXLE LOAD 34,400 LBS.

NOTE:
* INCLUDES FULL LOAD FUEL
OIL, LUBR. OIL, WATER, SAND,
ALL EQUIP. AND 2 MEN.

BUILDERS LOT NO 01-5124

DROP BOTTOM GONDOLA, CLASS G-5
BUILT BY AMERICAN CAR & FOUNDRY CO
AFE T.S. 5-57

CAR NOS T.S. 201-205
ORIG NO OF CARS 5

ALL CARS EQUIPPED WITH
LUBRICATOR PADS

POWER HAND BRAKE

4-10 3/8 OVER RAIL
STAKES
-10 7/8 OVER CORNER
PADS
-9 9/8 INSIDE

TYPE A CAST
STEEL WHEELS

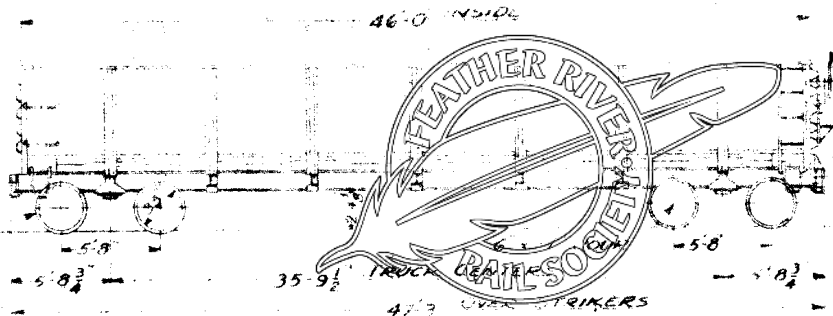

16 LIFT DOORS

LIFTING MECHANISM
BY ENTERPRISE RLY EQUIP CO

ASF A-3 RIDE CONTROL TRUCKS
CARDWELL-WEST NY-11-F DRAFT GEAR
WESTINGHOUSE TYPE AB 1012 AIR BRAKES

LENGTH INSIDE
WIDTH
HEIGHT

46'-0"
4'-9 7/8"
5'-4"

CAPACITY

140,000 LBS
2410 CUFT
LEVEL FULL

WEIGHT - BODY
TRUCKS
TOTAL 56,300 LBS

BUILDERS LOT NO 8240

BOX CAR, CLASS XM
 BUILT BY PULLMAN STANDARD CAR MFG. CO.
 AFE T.S. 23-55.

CAR NOS. T.S. 501-525
 ORIG No. OF CARS 25

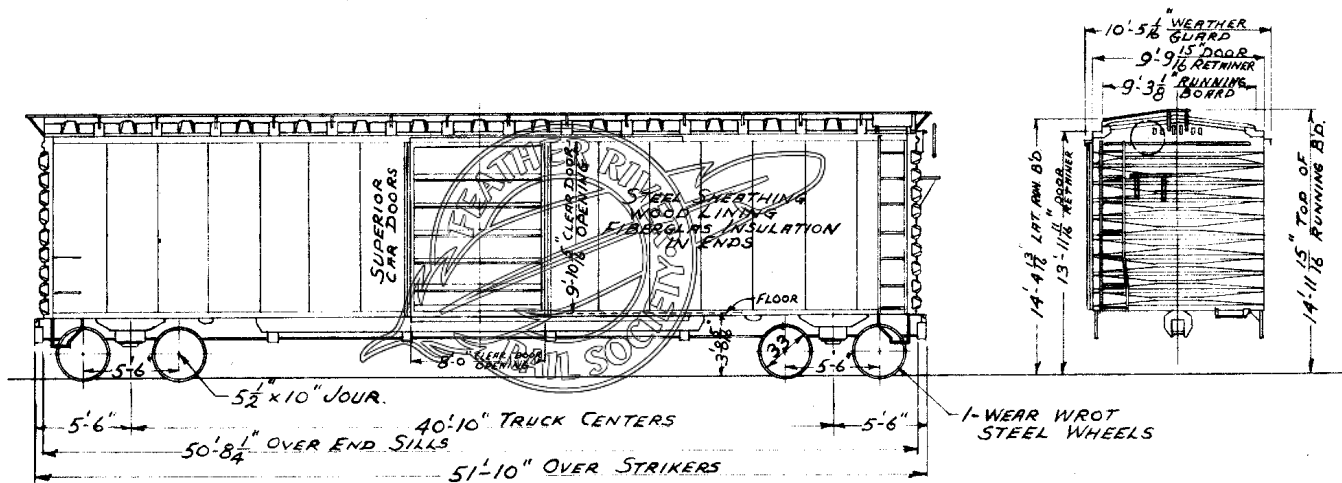

SCULLIN A-3 RIDE CONTROL TRUCKS
 N.M. & S.C. CO. TYPE MF-275 RUBBER DR. GEAR
 WESTINGHOUSE TYPE AB-1012 AIR BRAKES

LENGTH INSIDE	50'-5 9/16"
WIDTH	9'-2 1/16"
HEIGHT	10'-5 1/2"

CAPACITY	100000 LBS.
	4844 CU. FT.

WEIGHT - BODY TRUCKS	
TOTAL	52000 LBS

BUILDERS LOT No. WP-57.

INSULATED BOX CAR, CLASS RBL
 BUILT BY PACIFIC CAR & FOUNDRY CO.
 AFE T.S. 17-57.

CAR Nos. T.S. 601 - 610
 ORIG. No. OF CARS 10

TS 601-605, 1 WEAR WROT STL. WHEELS
 TS 606-610, TYPE "A" CAST STL. WHEELS
 CARS EQUIPPED WITH PC LOADERS:
 TS 601-608, 8 BELTS
 TS 609-610, 6 BELTS.

601-605	606-610	
ROLLER BEARINGS	HYATT	TIMKEN
DRAFT GEAR	FR-16	MF-400

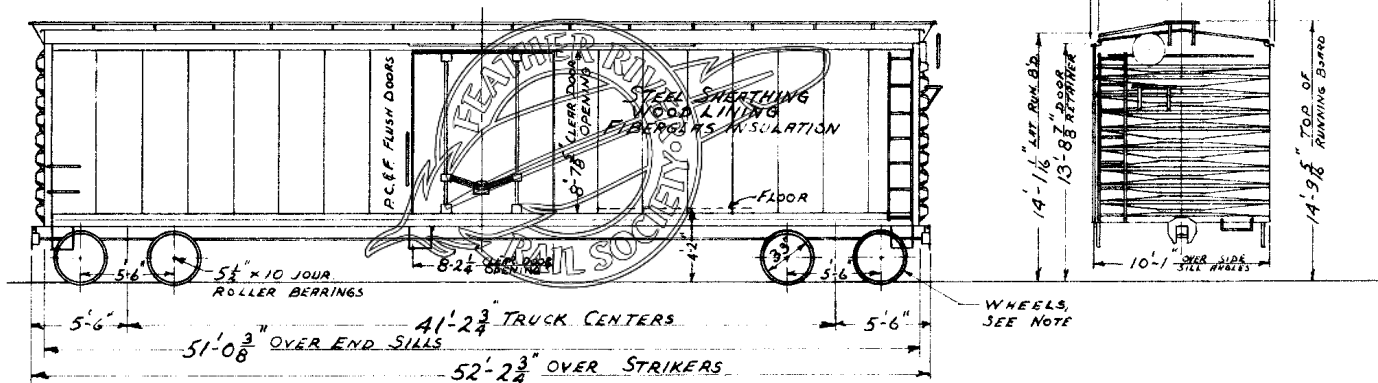

BARBER STABILIZED, TYPE S-2-C TRUCKS	LENGTH INSIDE	50'-0"	CAPACITY	97000 LBS.	WEIGHT - BODY
RUBBER DRAFT GEAR-SEE TABLE	WIDTH	9'-2"	"	4154 CU.FT.	TRUCKS
WESTINGHOUSE TYPE AB-1012 AIR BRAKES	HEIGHT	9'-1"			TOTAL 70900 LBS

BUILDERS LOT NO WP-58

INSULATED BOX CARS, CLASS RBL
 BUILT BY PACIFIC CAR & FOUNDRY DEC. 1958
 AFE T.S. 2-59

CAR NOS. T.S. 611-620
 T.S. 801-840
 NO OF CARS 50

NOTE:

TS 611-620 EQUIPPED WITH 6 BELT PC LOADERS - WIDTH INSIDE 9'-2" - TOTAL WT. 70200 LBS.

TS 801-840 EQUIPPED WITH 8 BELT DF LOADERS - WIDTH INSIDE 9'-1³/₄" - TOTAL WT. 71400 LBS.

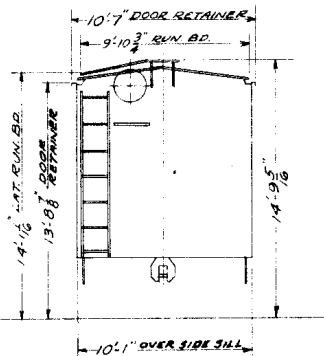
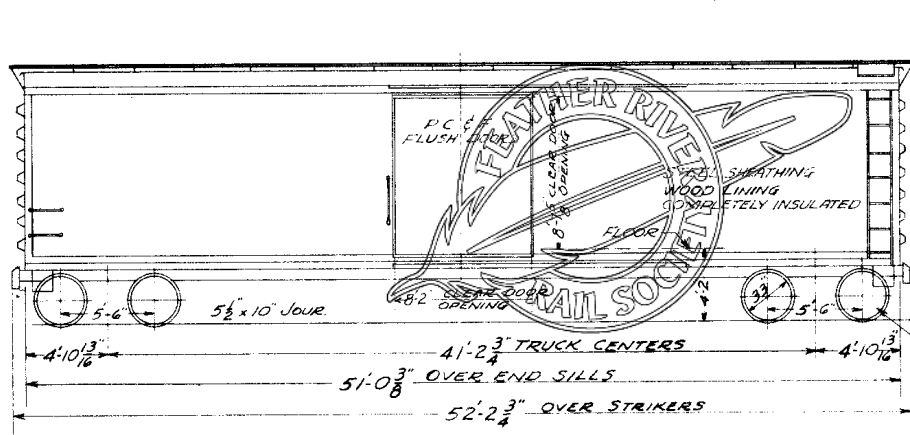

TS 611-620, TS 801-815, I.W. STEEL WHEELS
 TS 816-840, CAST STEEL WHEELS

BARBER S-2-C STABILIZED TRUCKS
 N.M. & S.C. Co. MF-400 RUBBER DRAFT GEAR
 AAR FRICTION BEARINGS

LENGTH INSIDE _____ 50'-6"
 WIDTH " _____ SEE NOTE
 HEIGHT " _____ 9'-1"

CAPACITY _____ 97000 LBS
 " _____ 4154 CU. FT.

WEIGHT BODY
 TRUCKS 14590
 TOTAL SEE NOTE